

# Nice

BiDi-Awning

## **Exterior bidirectional interface for tubular motor**

**EN** - Instructions and warnings for installation and use

**Nice**

## 1 WARNINGS AND GENERAL PRECAUTIONS

- **CAUTION! – This manual contains important instructions and warnings for personal safety.** Carefully read all parts of this manual. If in doubt, suspend installation immediately and contact the Nice Technical Assistance.
- **CAUTION! – Important instructions: keep this manual in a safe place to enable future product maintenance and disposal procedures.**
- **CAUTION! – All installation and connection operations must be performed exclusively by suitably qualified and skilled personnel with the unit disconnected from the mains power supply.**
- **CAUTION! – Any use other than that specified herein or in environmental conditions other than those stated in this manual is to be considered improper and is strictly forbidden!**
- The product's packaging materials must be disposed of in full compliance with local regulations.
- Never apply modifications to any part of the device. Operations other than those specified may only cause malfunctions. The manufacturer declines all liability for damage caused by makeshift modifications to the product.
- Never place the device near to sources of heat and never expose to naked flames. These actions may damage the product and cause malfunctions.
- This product is not intended for use by people (including children) with reduced physical, sensory or mental capabilities or who lack experience and knowledge, unless they have been given supervision or instruction concerning the use of the product by a person responsible for their safety.
- Make sure that children do not play with the product.
- Check the warnings in the instruction manual for the motor that the product is connected to.
- Handle the product with care, being sure not to crush, knock or drop it in order to avoid damage.

## 2 PRODUCT DESCRIPTION

The BiDi-Awning control unit enables the control of a single-phase asynchronous motor, mains powered, with connection types: Down, Common, Up, used for the automation of awnings, rolling shutters and similar.

The BiDi-Awning control unit incorporates a radio transceiver that operates at the frequency of 433.92 MHz with rolling code technology to guarantee optimal safety levels.

Each control unit can memorise up to 30 mono or bidirectional transmitters in the series ERA, ERGO, FLOR, NICEWAY and VERY, which enable the remote control of the unit.

In the 30 transmitters, climatic radio sensors can be memorised, for the automatic control of the control unit according to weather conditions. The control unit is equipped with overload, and overheating protection, which will disable the relays to prevent damage to the circuit.

## 3 INSTALLATION



- **The product is subject to hazardous electric voltages**
- **The installation of the BiDi-Awning and automations must be performed exclusively by technically qualified personnel, in observance of current legislation and standards, and according to these instructions. All connections must be made with the system disconnected from the power supply.**
- **Never perforate the BiDi-Awning container!**
- **The power supply line must be protected by suitable magneto-thermal (rated up to 16A) and residual-current circuit breakers.**
- **The control unit can be fitted directly in the shutter/awning box, double-sided tape can be used for this. To avoid the risk of water leaks it should be positioned with the cables towards the bottom. Do not place it with the cables towards the top.**

1. Switch off the mains power supply (fig. 1).
2. Open the container by removing the sealing cap (fig. 2).
3. Thread the two cables through the designated holes in the sealing cap (fig. 3)
4. Strip the motor cable and the power supply cable about 3 cm and then the single wires approx. 6 mm (fig. 4).
5. Pull the board a few centimetres out of the container (fig. 5).
6. Connect the wires to the terminals, observing the diagram in fig. 8 and the operations described in chapter 3.1, 3.2 and 3.3.
7. Push the board inside the container, make sure that the stripped length of the cable is fully inside the container (fig. 6).
8. Slide the sealing cap until the container closes completely (fig. 7).

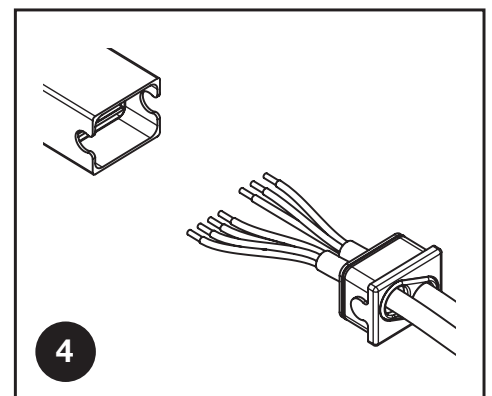
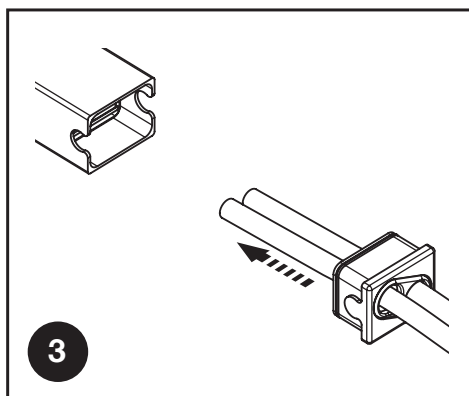
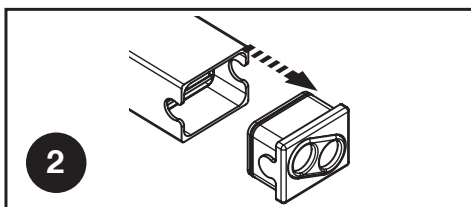
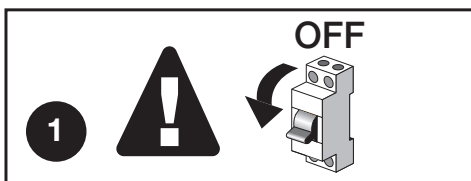

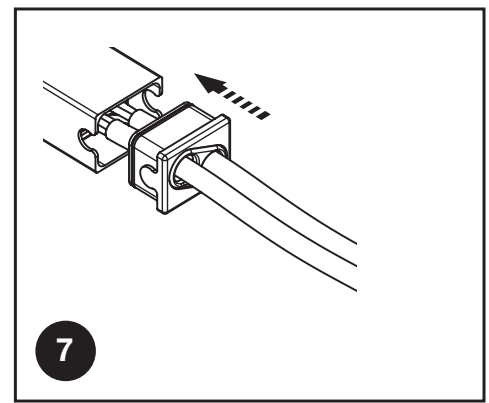
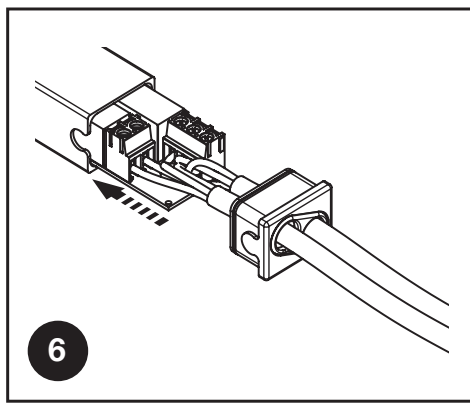
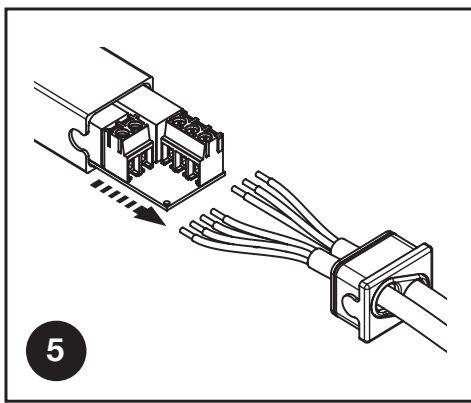

### 3.1 - Electrical connections

**⚠ ⚠** Carefully follow all the connection instructions. If you have any doubts do not make experiments but consult the relevant technical specifications which are also available on the web site: [www.niceforyou.com](http://www.niceforyou.com). An incorrect connection may be dangerous and cause damage to the system.

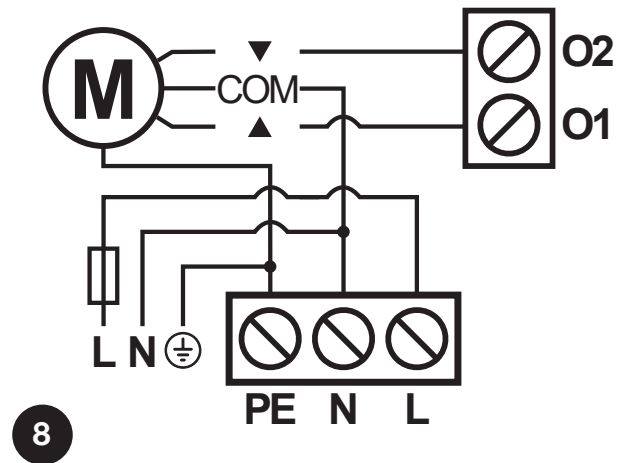

### 3.2 - Motor connection

The single phase asynchronous motor connection to the mains must be via terminals O1-N-O2-PE (Up, Common, Down, Earth). Up corresponds to the key ▲ (direction of wind speed sensor activation) of the transmitters, Down to key ▼ (by default for direction of sun sensor activation). After connecting, if the direction of motor rotation is incorrect, exchange the connections of terminals O1 and O2.

**⚠** Never connect more than one motor per control unit!

### 3.3 - Power supply

The electric power supply of the control unit must be connected by means of terminals L-N-PE (Live, Neutral, Earth). The BiDi-Awning control unit can operate with supply voltage of 100 to 240 Volts and frequency of 50 or 60 Hz.

## 4 MEMORISING TRANSMITTERS

- This chapter describes the memorisation procedures in Mode I, used to control a single automation with the 3 keys of the transmitters and Mode II, used to control an automation with a single key, thus leaving the other keys free for control of other automations.
  - The key ■ corresponds to the central key of the transmitters ERGO, PLANO and NICEWAY.
  - All memorisation sequences are timed, which means they must be completed within the set time limits.
  - With transmitters that envisage several “groups”, the relative group to associate with the control unit must be selected before proceeding.
  - Settings via radio are possible on all receivers located within the operating radius of the transmitter, and therefore only the device required for the operation should remain powered.
- ⚠** First memorised transmitter must be equipped with a programming key (PROG/PRG), otherwise the programming of the control unit’s functions will not be possible.





## 4.1 - Mode I

In Mode I the command associated with the transmitter keys is fixed (table A1). In Mode I only one memorisation phase is performed for each transmitter and only one memory location is occupied. During memorisation in Mode I it is not important which key is pressed on the transmitter.

Table A1 - Memorisation using Mode I	
Key	Command
Key ▲ or 1st channel	Up
Key ■ or 2nd channel	Stop
Key ▼ or 3rd channel	Down







## 4.2 - Memorising transmitters in Mode I

When there is no transmitter memorised, the first can be memorised during startup according to the following procedure.





Table A2 - Memorising first transmitter during startup in Mode I		Example
01.	Connect the control unit to the power mains, confirmed by 2 beeps.	
02.	Within 10 seconds: <ul style="list-style-type: none"> <li>• <b>Monodirectional transmitters:</b> press and hold any key of the transmitter to be memorized for at least 3 seconds.</li> <li>• <b>Bidirectional transmitters:</b> press any key of the transmitter to be memorized</li> </ul>	MONO:  BIDI: 
03.	If the memorisation procedure is successful, you will hear 3 beeps.	

If no transmitters should be memorized during startup, the programming procedure concludes automatically after 10 seconds and you will hear one long beep.

The transmitters can be memorised using the programming key of the already memorized transmitter according to the following procedure.

Table A3 - Memorising other transmitters in Mode I		Example
01.	Press the programming key of the already memorised transmitter.	
02.	Wait until you hear 2 beeps.	
03.	Press the key ▼ (or third channel) to enter the programming mode, you will hear 2 beeps.	
04.	Within 10 seconds: <ul style="list-style-type: none"> <li>• <b>Monodirectional transmitters:</b> press and hold any key of the transmitter to be memorized for at least 3 seconds.</li> <li>• <b>Bidirectional transmitters:</b> press any key of the transmitter to be memorized</li> </ul>	MONO:  BIDI: 
05.	If the memorisation procedure is successful, you will hear 3 beeps.	
06.	Repeat steps 4 and 5 to acquire all the remotes.	
07.	After 10 seconds that the device doesn't receive any signal, the programming procedure concludes automatically and you will hear one long beep.	

If transmitters have already been memorised, other transmitters can be memorised as described in the following procedure.

Table A4 - Memorising other transmitters with a previously memorised transmitter in Mode I		Example
01.	Press any key three times of a <b>previous</b> , memorised transmitter.	Old  x3
02.	Press the same key three times of a <b>new</b> transmitter.	New  x3
03.	Press the same key three times of a <b>previous</b> , memorised transmitter.	Old  x3
04.	Press the same key of the <b>new</b> transmitter.	New 
05.	If the memorisation procedure is successful, you will hear 3 beeps.	
06.	The programming procedure concludes automatically.	

**Note.** If the memory is full (30 transmitters memorised) you will hear 6 beeps and the transmitter cannot be memorised.

### 4.3 - Mode II









In Mode II each key of the transmitter can be associated with one of 10 possible commands (table A5); for example, one automation can be controlled with just one key memorised for the Step-by-step command, while the other keys are left free for control of other automations. In Mode II one memorisation phase is performed for each key and each occupies one location in the memory. During Mode II memorisation, the specific key pressed is memorised. If another key is to be assigned a command on the same transmitter, a new memorisation phase must be performed for that specific key.

**Warning! - For the partial positions to work correctly, you must perform the calibration procedure (see chapter 5.1).**

Table A5 - Memorisation using Mode II	
N°	Command
1	Step-by-step (Up-Stop-Down-Stop... )
2	Go to position level 5%
3	Go to position level 25%
4	Go to position level 50%
5	Go to position level 75%
6	Up
7	Down
8	Stop
9	“Hold-to-run” Down*
10	“Hold-to-run” Up*

\* “Hold-to-run” command is not be available in some transmitters.

### 4.4 - Memorising transmitters in Mode II





Table A6 - Memorising first and other transmitters in Mode II		Example
01.	Press the programming key of the already memorised transmitter.	
02.	Wait until you hear 2 beeps.	
03.	Press the programming key the number of times corresponding to the required command (1 = Step-by-Step, 2 = go to position level 5%, 3 = go to position level 25%, 4 = go to position level 50%, 5 = go to position level 75%, 6 = Up, 7 = Down, 8 = Stop, 9 = Hold-to-run Down, 10 = Hold-to-run Up).	1-10 
04.	Check that the buzzer sounds with number of beeps corresponding to the required command.	1-10 
05.	Within 10 seconds: <ul style="list-style-type: none"> <li><b>Monodirectional transmitters:</b> press and hold the required key of the transmitter to be memorized for at least 3 seconds.</li> <li><b>Bidirectional transmitters:</b> press the required key of the transmitter to be memorized</li> </ul>	MONO:  3s  BID: 
06.	If the memorisation procedure is successful, you will hear 3 beeps.	
07.	Repeat steps 5 and 6 to acquire all the remotes with the same command.	
08.	Repeat steps 3 to 6 to acquire all the remotes with another command.	
09.	After 10 seconds that the device doesn't receive any signal, the programming procedure concludes automatically and you will hear one long beep.	

**Note.** If the memory is full (30 transmitters memorised) you will hear 6 beeps and the transmitter cannot be memorised.

### 4.5 - Memorising a new transmitter using the “enabling code” of an already memorised transmitter

The bidirectional transmitter has a secret code, the so-called “enabling code”. By transferring this code from a memorized transmitter to a new transmitter, the latter is recognized (and memorized) automatically by the control unit. Please refer to the manual of the transmitters for further details.

**Warning! - The enabling code can only be transferred between two transmitters that have the same radio coding.**





Table A7 - Transmitting the “enabling code”		Example
01.	Bring a <b>previous</b> , memorised transmitter and the <b>new</b> transmitter close to one another.	
02.	On the <b>new</b> transmitter press command key. The LED of the <b>previous</b> transmitter will switch on and start flashing.	New  Old 
03.	On the <b>previous</b> transmitter press command key.	Old 
04.	Once the code has been transferred, for an instant both the transmitters will vibrate and the green LED will light up signalling end of the procedure. When the <b>new</b> transmitter will be used, for the first 20 times it will transmit this “enabling code” to the receiver together with the command. The receiver will automatically memorize the identification code of the transmitter that transmitted it	

## 5.1 - Calibration









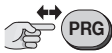

During calibration process the device learns the position of the Up and Down limit positions. The calibration can be performed automatically or manually. During the automatic calibration the motor will perform Up, Down and Up again manoeuvres to recognize the limit positions. During the manual calibration limit positions must be saved manually while the motor performs Up/Down manoeuvres.

**⚠ If the automatic calibration was not able to properly recognize the limit positions, perform the manual calibration instead. The control unit will calibrate itself after the user performs two full manoeuvres (Up to Down and Down to Up), but performing the calibration according to one of the procedures below is recommended before operation.**

To perform automatic calibration, proceed as described below.

Table A8 - Automatic calibration		Example
01.	Press the programming key of the already memorised transmitter.	
02.	Wait until you hear 2 beeps.	
03.	Press key ■ (or second channel) of the transmitter.	
04.	The motor will complete Up, Down and Up again maneuvers automatically.	
05.	The programming procedure concludes automatically upon finishing 2 complete maneuvers and you will hear one long beep.	

To perform calibration manually, proceed as described below. Perform manual calibration only when automatic doesn't work.

Table A9 - Manual calibration		Example
01.	Press the programming key of the already memorised transmitter.	
02.	Wait until you hear 2 beeps.	
03.	Press key ▲ (or first channel) of the transmitter to start calibration.	
04.	Device will start Up maneuver.	
05.	Press key ■ (or second channel) of the transmitter to set Up limit position.	
06.	Device will start Down maneuver.	
07.	Press key ■ (or second channel) of the transmitter to set Down limit position.	
08.	Device will start Up maneuver.	
09.	Press key ■ (or second channel) of the transmitter to set Up limit position.	
10.	The programming procedure concludes automatically and you will hear one long beep.	





## 5.2 - Partial position

The BiDi-Awning control unit enables setting a quickly accessible partial positions (which work only with transmitters memorized in Mode I).



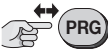

Table A10 - Available partial positions		
N°	Press at the same time to activate	Default position
1	▲ and ▼ 1st and 3rd channel S1 and S2	50% (of the moving time)
2	▲ and ■ 1st and 2nd channel	15% (of the moving time)

- ⚠ If the Venetian blinds mode is enabled (see chapter 5.3), by default (2nd partial position), the blinds stop at 15% and slats are rotated to 10%.**
- If the Venetian blinds mode is disabled, by default (2nd partial position), the shutter stops at 15%.**
- In order for the partial positions to work, the calibration must be performed.**
- Pressing S1 and S2 at the same time might not be possible for some types of pushbuttons/switches.**

To set new position for 1st partial position, proceed as described below.





Table A11 - Setting 1st partial position		Example
01.	Press the programming key of the already memorised transmitter.	
02.	Wait until you hear 2 beeps.	
03.	Press the keys ▲ and ▼ (or first and third channel) at the same time to enter the programming mode, you will hear 2 beeps.	
04.	Bring the shutter/blind/awning at your desired partial position (or press ▲ and ▼ or 1st and 3rd channel at the same time to disable the 1st partial position altogether).	
05.	Save and conclude the programming by pushing the programming pushbutton, you will hear one long beep (fig. 1).	

To set new position for 2nd partial position, proceed as described below.

Table A12 - Setting 2nd partial position		Example
01.	Press the programming key of the already memorised transmitter.	
02.	Wait until you hear 2 beeps.	
03.	Press the keys ▲ and ■ (or first and second channel) at the same time to enter the programming mode, you will hear 2 beeps.	
04.	Bring the shutter/blind/awning at your desired partial position (or press ▲ and ■ or 1st and 2nd channel at the same time to disable the 2nd partial position altogether).	
05.	Save and conclude the programming by pushing the programming pushbutton, you will hear one long beep (fig. 1).	

### 5.3 - Virtual Limit Switch









If needed, it is also possible to set a virtual limit switch, limiting the shutter/blind/awning movement to the specified position (range).

Table 13 - Setting a virtual limit switch		Example
01.	Bring the shutter/blind/awning at your desired position (virtual limit switch position).	
02.	Press the programming key of the already memorized transmitter	
03.	Wait until you hear 2 beeps.	
04.	Press and hold the key ▲ (or first channel) for 2 seconds until you hear 1 long beep to confirm the position programmed • If the buzzer makes 5 short beeps, BiDi-Awning wasn't calibrated before.	
05.	Press the key of the transmitter to select the limit you want to keep as reference: • ▲ or first channel - the top limit is your reference limit switch, • ▼ or third channel - the bottom is your reference limit switch.	
06.	The motor will make a move between the virtual and mechanical limit switch.	
07.	The programming procedure concludes automatically.	

## 5.4 - Venetian blinds

The BiDi-Awning control unit enables the control of slats for Venetian blinds. When the Venetian blinds control is enabled, pressing ▲/1st channel or ▼/3rd channel will move the slats by 20% and the normal Up and Down maneuvers must be performed by pressing and holding the corresponding keys. For the function to work properly, time of full slats movement must be adjusted. By default, the Venetian blinds function is disabled and full movement time is set to 1.5s.

To enable or disable the Venetian blinds control and set the slats movement time, proceed as described below.

Table A14 - Setting Venetian blinds behavior		Example
01.	Press the programming key of the already memorised transmitter.	
02.	Wait until you hear 2 beeps.	
03.	Press the keys ■ and ▼ (or second and third channel) at the same time to enter the programming mode.	
04.	If after 5 sec. the buzzer emits 2 beeps, the Venetian blinds mode is enabled, if it emits 1 beep the Venetian blinds mode is disabled.	
05.	Press key ▲ (or first channel) of the transmitter to toggle the setting, the buzzer informs about the current setting: <ul style="list-style-type: none"> <li>• 2 beeps – Venetian blinds control enabled</li> <li>• 1 beep – Venetian blinds control disabled</li> </ul>	
06.	Press the programming key the number of times corresponding to the required time (1 = 250ms, 2 = 500ms, 3 = 750ms, 4 = 1s, 5 = 1.25s, 6 = 1.5s, 7 = 1.75s, 8 = 2s, 9 = 2.25s, 10 = 2.5s, 11 = 2.75s, 12 = 3s).	1-12 
07.	Check that the buzzer sounds with number of beeps corresponding to the required time.	1-12 
08.	After 10 seconds that the device doesn't receive any signal, the programming procedure concludes automatically and you will hear one long beep.	

## 5.5 - Climatic sensors

The control unit supports Nice radio mono and bidirectional climatic sensors. Memorisation of a climatic sensor must be carried out like that of a normal transmitter (follow procedure in table A3). Thresholds for commands must be programmed on the climatic sensor.

Commands connected to Wind are given priority, followed by the sun and rain. Reactions to sun/rain can be turned on/off using the button Sun ON/OFF (by default the reactions are turned on). Please refer to the manual of the climatic sensor for further details.

Table A15 - Response to climatic commands	
Command	Response
Sun ON	Go to Down position (default) or partial position (set according to table A16)
Sun OFF	Go to Up position
Rain ON	Go to Down (default) or Up position (set according to table A17)
Rain OFF	Go to Up (if went Down for Raining) <b>or</b> Nothing happens (if went Up for Raining)
Wind ON	Go to Up position and block the motor control until receiving Wind OFF
Wind OFF	Unblock the motor control





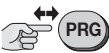









Table A16 - Setting response to Sun ON command		Example
01.	Press the programming key of the already memorised transmitter.	
02.	Wait until you hear 2 beeps.	
03.	Press and hold the key ■ (or second channel) for 2 seconds until you hear 1 long beep.	
04.	Press key of the transmitter to select response to Sun ON command: <ul style="list-style-type: none"> <li>• ▼ (or third channel) – go to Down position (default)</li> <li>• ▲ (or first channel) – go to partial position</li> </ul>	
05.	Currently set response to Sun ON command will be confirmed with beeps: <ul style="list-style-type: none"> <li>• 2 long beep – go to Down position</li> <li>• 4 long beeps – go to partial position</li> </ul>	
06.	The programming procedure concludes automatically.	



Table A17 - Setting response to Rain ON command		Example
01.	Press the programming key of the already memorised transmitter.	
02.	Wait until you hear 2 beeps.	
03.	Press and hold the key ▼ (or third channel) for 2 seconds until you hear 1 long beep.	
04.	Press key of the transmitter to select response to Raining command: <ul style="list-style-type: none"> <li>▼ (or third channel) – go to Down position (default)</li> <li>▲ (or first channel) – go to Up position</li> </ul>	
05.	Currently set response to Raining command will be confirmed with beeps: <ul style="list-style-type: none"> <li>2 long beep – go to Down position</li> <li>4 long beeps – go to Up position</li> </ul>	
06.	The programming procedure concludes automatically.	





### 5.5 - Deleting transmitters

If memorised transmitters and settings need to be deleted, proceed as described below.

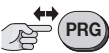
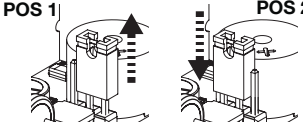

Table A18 - Deleting transmitter from memory		Example
01.	Press 5 times the programming key of the already memorised transmitter.	5x 
02.	The buzzer will confirm with 5 beeps.	
03.	Press any key on the acquired transmitter to remove it from memory.	
04.	3 beeps confirm the correct removal.	
05.	After 10 seconds that the device doesn't receive any signal, the programming procedure concludes automatically and you will hear one long beep.	

### 5.6 - Factory reset

If the control unit needs to be reset to the factory settings (all transmitters and setting will be deleted), proceed as described below.

Table A19 - Restoring to factory defaults with already memorised transmitter		Example
01.	Press 5 times the programming key of the already memorised transmitter.	5x 
02.	The buzzer will confirm with 5 beeps.	
03.	Press the programming key.	
04.	5 beeps confirm the correct reset.	
05.	The programming procedure concludes automatically and you will hear one long beep. Afterwards the control unit will initiate the start-up procedure according to table A2.	

If the first memorized transmitter is inoperable, lost or is not equipped with the programming key, you can reset the control unit to the factory settings with not memorized transmitter, proceed as described below.

Table A20 - Restoring to factory defaults with not memorised transmitter		Example
01.	Switch the control unit off.	
02.	Change the position of the jumper from position 1 to position 2.	
03.	Power the control unit.	
04.	The buzzer will confirm restoring to factory defaults with 5 beeps.	
05.	Remember to change the position of the jumper back from position 2 to position 1 with disabled power.	

**Note.** If the jumper's position is not changed back to position 1, the device will be blocked, and after 10 seconds, it will start emitting a sound to inform the user that the process is not finished.

## 6 TECHNICAL SPECIFICATIONS

The product BiDi-Awning is produced by Nice S.p.a. (TV). Warnings: - All technical specifications stated in this section refer to an ambient temperature of 20 °C ( $\pm 5$  °C) - Nice S.p.a. reserves the right to apply modifications to the product at any time when deemed necessary, while maintaining the same functionalities and intended use.

<b>BiDi-Awning</b>	
Type	Operating control unit for electric motor; Type 1.B Action
Construction of control	Independently mounted control
Power supply	100–240 V AC, 50/60 Hz
Motor rated current	2 A
Motor rated power	480 VA for $V_n = 240$ V; 460 VA for $V_n = 230$ V; 240 VA for $V_n = 120$ V; 200 VA for $V_n = 100$ V
Supply Connection	External conductor
Recommended wires cross-section	0.5–4 mm <sup>2</sup> for 1 wire; 0.5–1.5 mm <sup>2</sup> for 2 wires
Overvoltage category	II
Rated impulse voltage	2500 V
Pollution degree	2
Protection against electric shock class	Class I control
Casing protection rating	IP 55
Operating temperature	-20 °C .. +50 °C
Shipping and storage temperature	-20 °C .. +50 °C
Dimensions (mm)	98 x 26 x 20
Weight	45 g

<b>Radio transceiver</b>	
Frequency band	433.05–434.04 MHz
Code	OPERA/FLOR (rolling code), PLN2+ (rolling code)
No. of memorisable transmitters	30, including climatic sensors
Transceiver range	Estimated at 150 m in open space and 20 m inside buildings (*)
Max. transmit power	10 dBm

(\*) The transceiver range is strongly influenced by other devices operating at the same frequency with continuous transmission, such as alarms and radio headphones which interfere with the control unit transceiver.

## 7 PRODUCT DISPOSAL

This product is an integral part of the automation and therefore must be disposed together with the latter.

As in installation, also at the end of product lifetime, the disassembly and scrapping operations must be performed by qualified personnel. This product is made of various types of material, some of which can be recycled while others must be scrapped. Seek information on the recycling and disposal systems envisaged by the local regulations in your area for this product category.

**Caution!** – some parts of the product may contain pollutant or hazardous substances which, if disposed of into the environment, may cause serious damage to the environment or physical health.

As indicated by the symbol alongside, disposal of this product in domestic waste is strictly prohibited. Separate the waste into categories for disposal, according to the methods envisaged by current legislation in your area, or return the product to the retailer when purchasing a new version.

**Caution!** – local legislation may envisage serious fines in the event of abusive disposal of this product.



## 8 DECLARATION OF CONFORMITY

Hereby, NICE S.p.A., declares that the radio equipment type BiDi-Awning is in compliance with Directive 2014/53/EU.

The full text of the EU declaration of conformity is available at the following internet address: <http://www.niceforyou.com/en/support>



**Nice SpA**  
Oderzo TV Italia  
info@niceforyou.com

[www.niceforyou.com](http://www.niceforyou.com)