

# Nice

## TUB4000

CE

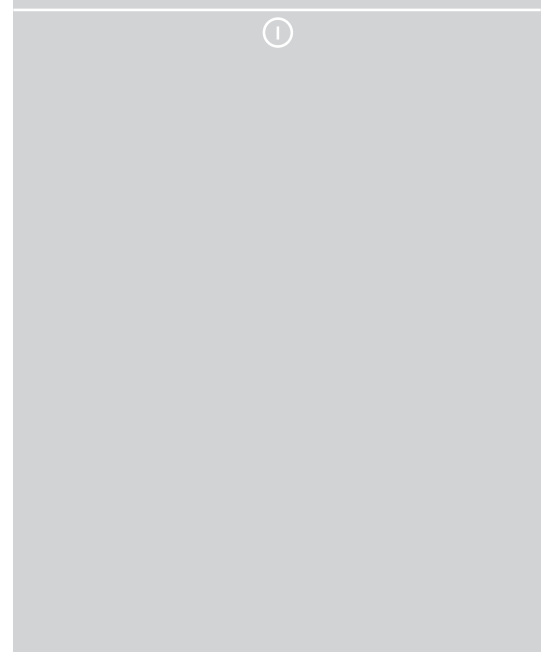

### For industrial sliding gates

**EN** - Instructions and warnings for installation and use

**IT** - Istruzioni ed avvertenze per l'installazione e l'uso

**FR** - Instructions et avertissements pour l'installation et l'utilisation

**ES** - Instrucciones y advertencias para la instalación y el uso

**DE** - Installierungs-und Gebrauchsanleitungen und Hinweise

**PL** - Instrukcje i ostrzeżenia do instalacji i użytkowania

**NL** - Aanwijzingen en aanbevelingen voor installatie en gebruik

**RU** - Инструкции и предупреждения по монтажу и эксплуатации

**Nice**



**▲ The following warnings are taken directly from the Regulations and apply, as far as possible, to the product described herein**

**CAUTION Important safety instructions. Follow all instructions as improper installation may cause serious damage**

**CAUTION Important safety instructions. It is important for you to comply with these instructions for your own and other people's safety. Keep these instructions**

- Before commencing the installation, check the "Product technical specifications", in particular whether this product is suitable for automating your guided part. If it is not suitable, DO NOT continue with the installation.
- The product cannot be used before it has been commissioned as specified in the chapter on "Testing and commissioning"

**CAUTION According to the most recent European legislation, the implementation of an automation system must comply with the harmonised standards provided by the Machinery Directive in force, which enables declaration of the presumed conformity of the automation. Taking this into account, all operations regarding connection to the electricity mains supply, as well as product testing, commissioning and maintenance, must be performed exclusively by a qualified and skilled technician!**

- Before proceeding with the installation of the product, check that all materials are in good working order and suited to the intended applications
- The product is not intended for use by persons (including children) with reduced physical, sensory or mental capacities, nor by anyone with insufficient experience or familiarity.
- Children must not play with the appliance
- Do not allow children to play with the control devices of the product. Keep the remote controls out of reach of children.

**CAUTION In order to avoid any danger from inadvertent resetting of the thermal cut-off device, this appliance must not be powered through an external switching device, such as a timer, or connected to a supply that is regularly powered or switched off by the circuit**

- Provide a disconnection device (not supplied) in the plant's mains power supply, with a contact opening distance that permits complete disconnection under the conditions dictated by overvoltage category III
- Handle the product with care during installation, taking care to avoid crushing, denting or dropping it, or allowing contact with liquids of any kind. Keep the product away from sources of heat and naked flames. Failure to observe the above can damage the product, and increase the risk of danger or malfunction. If this should happen, stop installation immediately and contact Customer Service.
- The manufacturer assumes no liability for damage to property, items or persons resulting from non-compliance with the assembly instructions. In such cases the warranty for material defects is excluded
- The weighted sound pressure level of the emission A is lower than 70 dB(A)
- Cleaning and maintenance to be carried out by the user must not be carried out by unsupervised children
- Before working on the system (maintenance, cleaning), always disconnect the product from the mains power supply
- Check the system periodically, in particular all cables, springs and supports to detect possible imbalances, signs of wear or damage. Do not use if repairs or adjustments are necessary, because a failure with the installation or an incorrectly balanced automated system may lead to injury
- The packing materials of the product must be disposed of in compliance with local regulations
- Keep persons away from the gate when it is moved through the control elements
- When performing a manoeuvre, keep an eye on the automated mechanism and keep all bystanders at a safe distance until the movement has been completed
- Do not operate the automation if anyone is working on it; disconnect the power supply before permitting any work to be carried out
- If the power cable is damaged, it must be replaced by the manufacturer or by the latter's technical assistance service, or by a similarly qualified person, in order to prevent any type of risk

## INSTALLATION PRECAUTIONS

- Prior to installing the drive motor, check that all mechanical components are in good working order and properly balanced, and that the automation moves correctly
- If the gate or door being automated has a pedestrian gate, then the system must include a control device that will inhibit the operation of the motor when the pedestrian gate is open
- Make sure that the control devices are kept far from moving parts but nonetheless in a visible position.  
Unless a selector is used, the control devices must be installed at a height of at least 1.5 m and must not be accessible

## Special warnings in relation to European directives applicable to the product

- "Construction Products" Regulation: Special warnings for this product in relation to Regulation 305/2011:
  - The full installation of this product, as described in this instruction manual and for certain types of use (e.g. excluding use solely for vehicles) may cause the product to fall within the scope of Regulation No. 305/2011 and its harmonised standard EN 13241-1.
  - It is necessary to apply all the installation criteria to ensure that the product meets the essential requirements of Regulation No. 305/2011; the installer must check and make sure that all these criteria have been scrupulously complied with.
  - The essential requirements might not be guaranteed if the product is installed and used without compliance with one or more of these criteria. It is forbidden to use the product in such circumstances until the installer has verified compliance with the Directive requirements; in this case the "ES13241-1.4870" label attached to the product must be removed immediately and the "EC Declaration of Conformity" (Annex I to this manual) cannot be used. As a result, the installer in turn becomes the manufacturer of the product and must comply with the provisions of Regulation No. 305/2011 and its harmonised standard EN 13241-1. In this case the product must be considered as "partly-completed machinery" and the "Declaration of Conformity" of Annex II can be used (for inclusion in the technical documentation).
- "Low Voltage" Directive:
 

Special warnings regarding the fitness of use of this product in relation to the "Low Voltage" Directive. This product meets the requirements in the "Low Voltage" Directive, if used for the use and in the configurations specified in this instruction manual and in combination with the items in the Nice S.p.A. product catalogue.

If the product is used in unspecified configurations or with other unspecified products, the requirements may not be guaranteed; the use of the product in such circumstances is prohibited until the installer has verified compliance with the specified requirements of the directive.

- “Electromagnetic compatibility” Directive:  
Special warnings regarding the fitness of use of this product in relation to the “Electromagnetic compatibility” Directive.  
This product has been subjected to electromagnetic compatibility tests in the most critical situations of use and in the configurations specified in this instruction manual and in combination with the items in the Nice S.p.A. product catalogue.  
If the product is used in unspecified configurations or with other unspecified products, the electromagnetic compatibility may not be guaranteed; the use of the product is prohibited in such circumstances until the installer has verified compliance with the specified requirements of the directive.

### Installation criteria and special warnings in connection with essential requirements

- When installed correctly, this product meets the essential requirements laid down in Regulation No. 305/2011 according to the requirements in harmonised standard EN 13241-1, as indicated in Table 1 and in the European directive on “Machinery” 2006/42/EC.
- Release of dangerous substances:  
The product does not contain and/or release hazardous substances in accordance with the requirements of EN 13241-1, 4.2.9 and according to the list of substances on the website of the European Community  
Special warning to ensure the continued compliance with the requirement – It is essential that the other materials used in the installation, such as electrical cables, comply with this requirement.
- Safe opening for horizontally moving doors: the product does not cause uncontrolled movements.  
Special warnings to ensure continued compliance of the requirements:
  - Install the product carefully following all the instructions described in Chapter “2 - Installation” and Chapter “4 - Testing and commissioning”.
  - Ensure that a maintenance schedule is organised which scrupulously complies with all the provisions in the Chapter “Maintenance Schedule”.
- As regards the risks of crushing and impact, the sliding closures are protected by means of one of these three methods:
  - 1** - For operation with “hold-to-run command” (man present): as specified in EN 12453, point 5.1.1.4. In this case the command button must be placed in view of the automation and if it is accessible to the public, the command button must not be available to them, e.g. use only with a key switch.
  - 2** - For “Semi-automatic” operation: through the use of an active sensitive edge for limiting the forces as specified in EN 12453, paragraphs 5.1.1.5 and 5.1.3.
  - 3** - For “automatic” operation: through the use of an active sensitive edge for limiting the forces as specified in EN 12453, paragraphs 5.1.1.5 and 5.1.3; in this case, at least one pair of photocells must be installed as shown in Fig. 2.

# TUB4000

ENGLISH

Instructions translated from Italian

## Contents

GENERAL WARNINGS: SAFETY - INSTALLATION - USE .....	1
1 - PRODUCT DESCRIPTION AND INTENDED USE .....	3
2 - INSTALLATION.....	3
2.1 - Tests prior to installation.....	3
2.2 - Product application limits .....	3
2.3 - Typical system .....	4
2.4 - Installation of the gear motor .....	4
2.5 - Installation of the various devices to the control unit .....	4
3 - ELECTRICAL CONNECTIONS .....	5
4 - TESTING AND COMMISSIONING.....	7
4.1 - Testing .....	7
5 - INTEGRATED CONTROL UNIT DPRO500 .....	8
5.1 - Product description and intended use .....	8
6 - INSTALLATION.....	8
6.1 - Tests prior to installation.....	8
6.2 - Product application limits .....	8
6.3 - Installation of the control unit .....	8
7 - ELECTRICAL CONNECTIONS .....	9
7.1 - Connecting the three-phase power supply cable .....	9
7.2 - Connecting the single-phase power supply cable.....	9
7.3 - Changing the power supply through the jumper .....	9
7.4 - Description of the electrical connections: power supply, safety and control devices, and accessories .....	9
7.5 - Electrical connections of the control unit .....	10
7.6 - STOP SAFETY EDGE input .....	12
7.7 - Connecting a radio receiver .....	12
7.8 - Initial startup and electrical connections test .....	12
7.9 - Total deletion of the control unit memory .....	12
7.10 - Recognition of the connected devices and the Opening and Closing positions.....	12
7.10.1 - Recognition of the Opening and Closing positions with mechanical limit switch.....	13
7.11 - Operating modes.....	13
7.12 - Overview programming unit.....	13
8 - TESTING AND COMMISSIONING.....	14
8.1 - Testing .....	14
8.2 - Commissioning .....	14
9 - INSTALLATION AND ELECTRICAL CONNECTION OF TWO CONTROL UNITS FOR LEAVES MOVING IN OPPOSITE DIRECTIONS.....	14
10 - FURTHER DETAILS AND DIAGNOSTICS.....	15
10.1 - Further details .....	15
10.1.1 - Signals when switching ON .....	15
10.1.2 - Other functions .....	15
10.2 - Diagnostics .....	16
11 - BASIC TROUBLESHOOTING.....	16
12 - PRODUCT DISPOSAL .....	17
13 - TECHNICAL SPECIFICATIONS .....	17
CE DECLARATION OF CONFORMITY.....	18
USER GUIDE (detachable insert) .....	19

**▲ IMPORTANT!**  
Before performing any type of operation or procedure, read carefully the general instructions (page 1) and the application limits (paragraph 2.2)

## 1 PRODUCT DESCRIPTION AND INTENDED USE

TUB4000 is a sliding gate gear motor of significant dimension for industrial use, with built-in control unit DPRO500 and is also prearranged for the inclusion of NICE receivers.

The gear motor, which functions electrically, can be disengaged by means of a key, thereby allowing the gate to be opened manually.

**CAUTION! – All uses other than the intended use described and use in environmental conditions other than those described in this manual should be considered improper and forbidden!**

## 2 INSTALLATION

**▲ The TUB4000 must be installed exclusively by qualified technical personnel in compliance with current laws, standards and regulations, and with the instructions provided in this manual.**

### 2.1 - Tests prior to installation

Before proceeding with installation, check the condition of the product components, suitability of the selected model and conditions of the intended installation environment:

- Check that all the materials are in good working order and suited to the intended use.
- Check that all conditions of use fall within the “application limits” of the product (paragraph 2.2) and the value limits shown in the “Product technical characteristics”.
- Check that the installation location is compatible with the overall dimensions of the product (**Fig. 1**).
- Check that the surface chosen for installing the product is solid and can ensure stable attachment.
- Make sure that the installation area is not subject to flooding; if necessary, the product may be installed, appropriately raised above ground level.
- Check that the space around the product allows safe and easy access.
- Check that all electrical cables to be used belong to the type listed in Table 2.
- Check that the automation has mechanical stops in both the opening and closing phases.

### 2.2 - Product application limits

The data relative to the TUB4000 performances is indicated in Chapter 13 (“Technical specifications”) and is the only data that allows for correctly determining whether the product is suitable for its intended use.

In general, TUB4000 is able to automate gates weighing up to 4,000 kg or up to 30 m long, according to the data shown in Table 1 below.

TABLE 1

Length of leaf in metres	Maximum cycles/hour
Up to 5	42
5÷10	21
10÷15	14
15÷20	10
20÷25	8
25÷30	7

Graphic representation of the cycles per hour in relation to the length of the gate leaf.

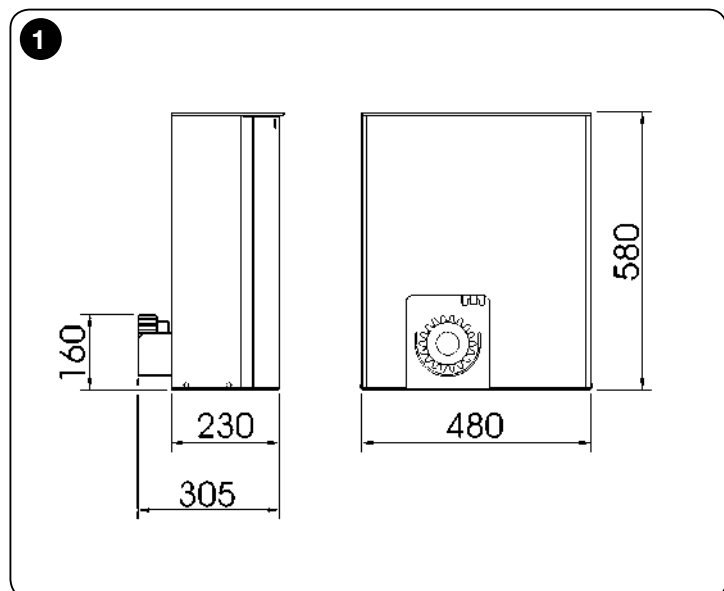
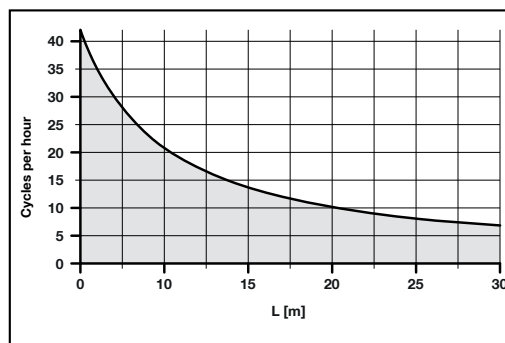

## 2.3 - Typical system

The **figure 2** below indicates a typical sliding gate automation system using the TUB4000.

- 1 Key operated selector switch
- 2 Photocell on post
- 3 FOTO photocells
- 4 Main fixed edge (optional)
- 5 Main moveable edge
- 6 "Open" stop bracket
- 7 Rack
- 8 Secondary fixed edge (optional)
- 9 Flashing light
- 10 Aerial
- 11 Motor
- 12 "Closed" stop bracket
- 13 Secondary moveable edge (optional)
- 14 Radio transmitter

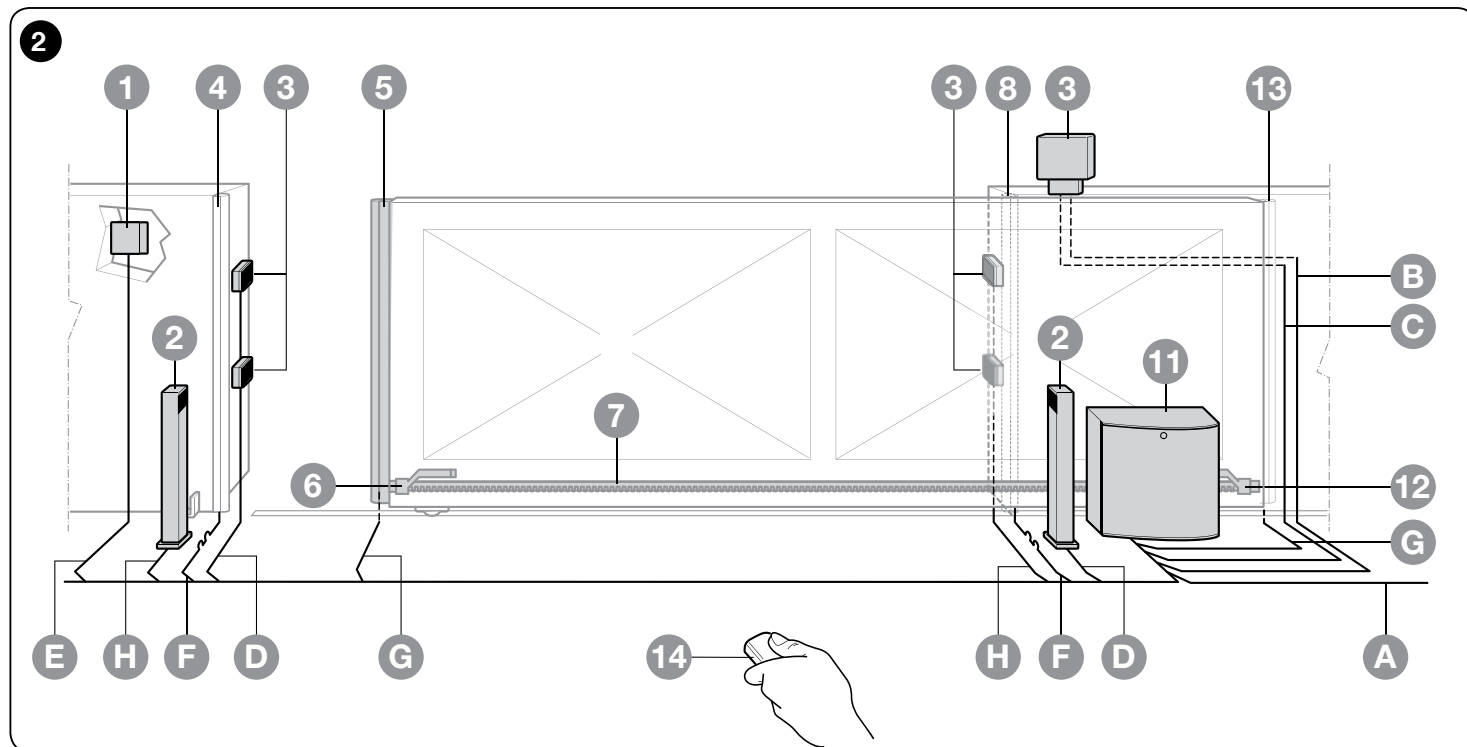

## 2.4 - Installation of the gear motor

If a base for the gear motor already exists, fixing must be performed directly to the surface by means of expansion bolts.

If this is not so, it is necessary to:

01. Dig an adequately large foundation hole.
02. Prepare one or more conduits for the electrical cables as shown in **fig. 5**.
03. Assemble the four clamps on the foundation plate setting one nut underneath and one on top of the plate as in **fig. 3** so that the threaded section protrudes out of the plate as much as possible.
04. Pour the concrete and, before it starts to harden, set the foundation plate checking that it is parallel to the leaf and perfectly level as shown in **fig. 5**. Wait for the concrete to harden completely.
05. Remove the body from the gear motor following the procedure shown in **fig. 7** in reverse order.
06. Place the gear motor on top of the foundation plate and make sure it is perfectly parallel to the leaf, then secure it by tightening the 4 nuts with washers to the respective clamps as shown in **fig. 6**.
07. Release the pinion as shown in the "Release and manual movement" paragraph in the Chapter "Instructions and Warnings for users of the TUB4000 gear motor".
08. Open the leaf up completely and place the first piece of the rack on the pinion and check that the beginning of the rack corresponds to the beginning of the leaf. Make sure that there is at least 2÷3 mm of play between the rack and the pinion, then fasten the rack to the leaf using suitable means.
09. Slide the leaf, using the pinion as a reference point for the fastening the other elements of the rack.
10. Cut away any excess of the rack.
11. Open and close the gate several times and make sure that the rack is aligned with the pinion with a maximum tolerance of 10- 15 mm. Moreover, check that the play of 2-3 mm between the pinion and the rack has been respected along the entire length.
12. Fix the two "Opening" and "Closing" limit switch brackets with the relative dowels to the outer sides of the rack as shown in **fig. 4**. Considering that the leaf will slide for a further 2÷3 cm after the limit switches have activated, the brackets should be positioned at a sufficient distance from the mechanical stops.
13. Perform the operation described in point 7 in reverse and block the pinion.

14. Secure the body to the TUB4000 as shown in **fig. 7** and ensure that the limit switch lever positioned above the pinion moves freely.

15. Close the gear motor door and make sure that the safety microswitch positioned to the right of the electric motor is activated.

**▲ In order to prevent the weight of the leaf from affecting the gear motor, it is important that there is a play of 2÷3 mm between the rack and the pinion.**

## 2.5 - Installation of the various devices to the control unit.

Perform the installation of all foreseen devices following the respective instructions. Check in Chapter 7 (DPRO500) which devices can be connected to the TUB4000.

**CAUTION! – The electrical connections must be performed by skilled and qualified personnel in strict observance of current legislation, standards and regulations with the system disconnected from electricity supply.**

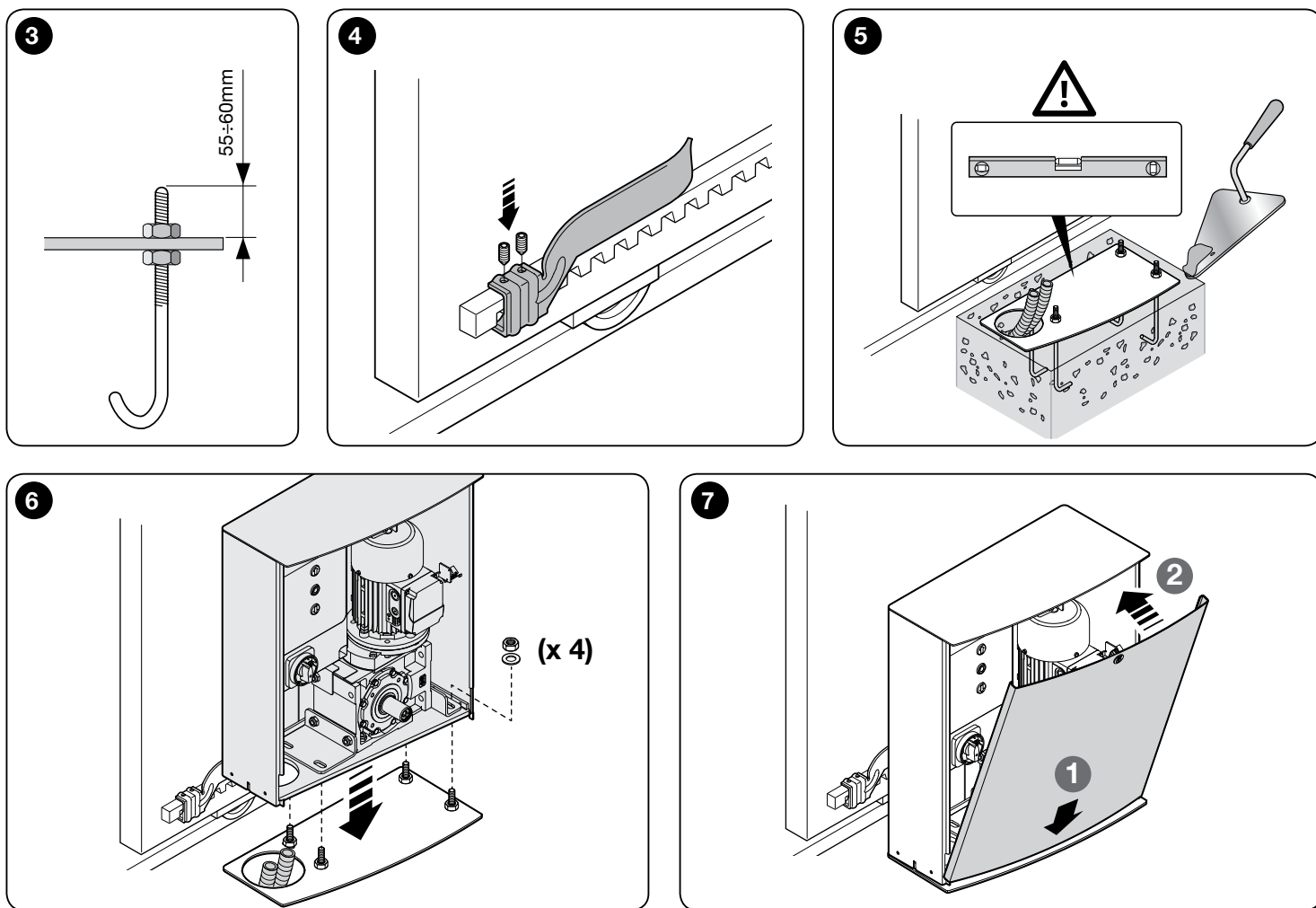

### 3 ELECTRICAL CONNECTIONS

Fig. 3 shows the cables needed for the connection of various devices in a typical installation; Table 2 shows the cable characteristics.

The cables used must be suitable for the type of installation. For example, an H05VV-F type cable is recommended for indoor applications or an H07RN-F if fitted externally.

TABLE 2 - Technical specifications of electrical cables (Fig. 2)

Connection	Cable type	Maximum admissible length
A: Power line	1 - 4x1.5mm <sup>2</sup> cable	30 m (note 1)
B: Flashing light	1 - 2x1mm <sup>2</sup> cable	20 m (note 7)
C: Aerial	1 RG58 type shielded cable	(recommended less than 5 meters)
D: Transmitter photocells	1 - 2x0.25mm <sup>2</sup> cable	30 m (note 3)
E: Key operated selector switch	2 - 2x0.25mm <sup>2</sup> cables	50 m (note 2)
F: Fixed edges	1 - 2x0.5mm <sup>2</sup> cable	30 m (note 4 - 6)
G: Moveable edges	1 - 2x0.5mm <sup>2</sup> cable	30 m (note 4 - 5 - 6)
H: Receiver photocells	2 - 2x0.25mm <sup>2</sup> cables	30 m (note 2 - 3)

**Note 1** – Power supply cables longer than 30 m may be used provided they have a larger gauge, e.g. 4x2.5mm<sup>2</sup>, and a safety earthing system is provided near the automation unit.

**Note 2** – A single 4x0.25mm<sup>2</sup> cable can be used instead of two 2x0.25mm<sup>2</sup> cables.

**Note 3** – Use shielded cables if the length exceeds 30 m, connecting the braid to earth only on the control unit side

**Note 4** – Several safety edges may be necessary in particular applications. See the instructions manual for the advised type of connection if there is more than one edge.

**Note 5** – Special devices which enable connection even when the leaf is moving must be used to connect movable edges to sliding leaves.

**Note 6** – The necessary number of conductors to connect the moveable and fixed edges depends on the method used to guarantee the required safety category. The example refers to the TCB65 edges connected to the TCE interface.

**Note 7** – It is possible to connect a 230 VAC warning light. See Fig. A for the connection.

**CAUTION!** – The cables used must be suited to the type of environment of the installation site.

After making the electrical connections, consult Chapter 7 (DPRO500) for information on the initial start-up procedures, and recognition of the safety devices and limit switches.

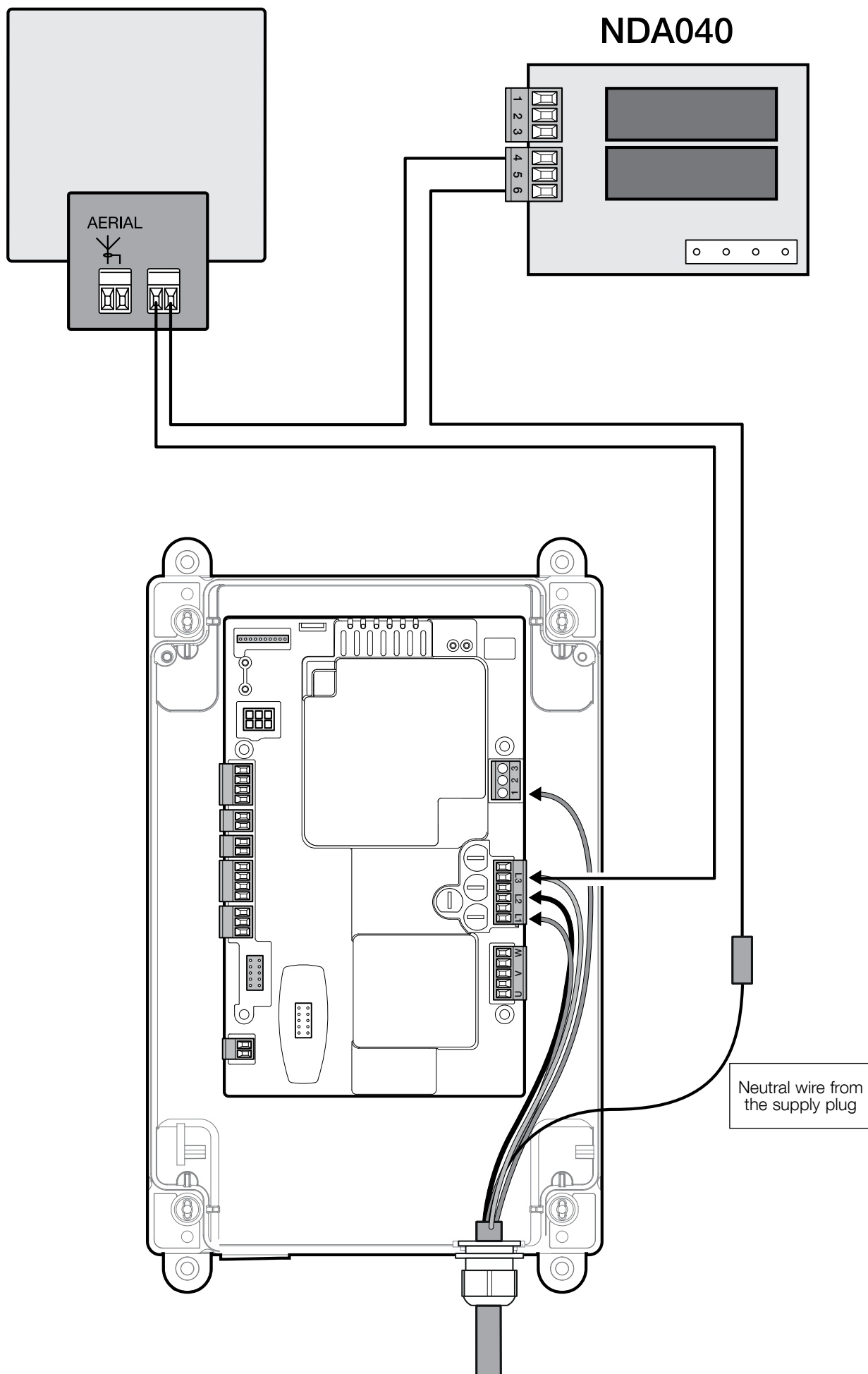



## 4 TESTING AND COMMISSIONING

The testing and commissioning phases are the most important when creating an automated system in order to ensure maximum safety. The testing procedure can also be performed as a periodic check of the automation devices.

These phases must be performed by qualified and experienced personnel who must take charge of establishing the tests necessary to verify the solutions adopted in respect of risks and verify the compliance of the system with applicable standards, legislation and regulations, in particular all requirements of the standard EN 12445 which establishes the test methods for checking automated systems for doors and gates. The additional devices must undergo specific testing, both in terms of their functions and in terms of their interaction with the control unit; therefore, you need to refer to the instruction manuals for the individual devices.

### 4.1 - Testing

The sequence of steps to be performed when running the testing phase, as described below, refers to a typical system (**Fig. 2**):

- 1 Check that all the instructions in the "Installation warnings" chapter have been rigorously complied with.
- 2 Using the control devices (transmitter, push button, key switch, etc.), test the Opening, Closing and Stopping of the gate, ensuring that the movement of the gate leaves corresponds to specifications. Test several times to assess the movement of the gate and check for any defects in assembly or adjustment and for any particular points of friction.
- 3 Check, one by one, that all the safety devices featured in the system (photo-cells, sensitive edges, etc.) work properly.
- 4 If the dangerous situations caused by the movement of the gate leaves have been safeguarded against by limiting the impact force, the impact force must be measured according to the EN 12445 standard.
- 5 Check that the stopping distance of the gate is 2-3 cm, otherwise adjust the mechanical brake as follows (**fig. 8**):
  - a. Give the nut on the motor shaft a half turn in a clockwise direction;
  - b. If the half turn isn't enough, turn the nut a little bit more;
  - c. Be careful not to over tighten the nut because it could completely block the electric motor.

**▲ Before adjusting the mechanical brake, the power supply must be turned off placing the main switch on the control unit in the "OFF" position.**

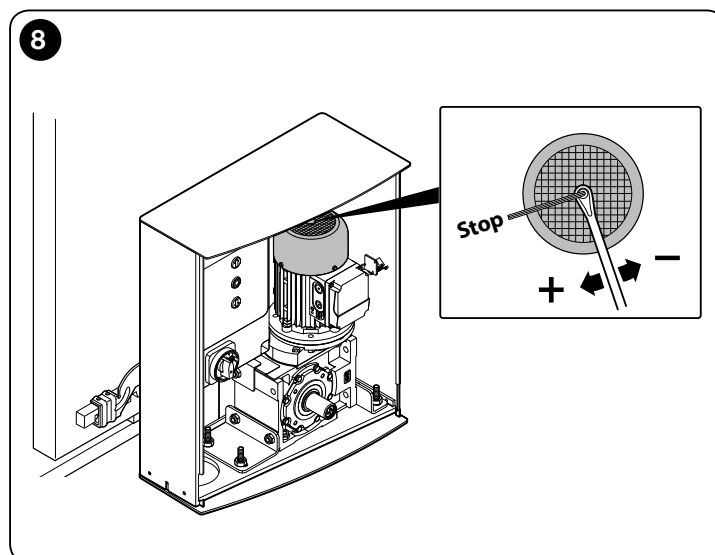

## 5 INTEGRATED CONTROL UNIT DPRO500



### ⚠ IMPORTANT!

Before performing any type of operation or procedure, read carefully the general instructions (page 1) and the application limits (paragraph 6.2)

### 5.1 - Product description and intended use

The **DPRO500** control unit is designed to control electromechanical actuators for automating gates, sectional doors or shutters.

**CAUTION! – All uses other than the intended use described and use in environmental conditions other than those described in this manual should be considered improper and forbidden!**

The control unit can be connected to all common safety elements. To open and close a gate, you only need to operate the appropriate button installed on the cover or the external button or via a radio receiver.

## 6 INSTALLATION

### 6.1 - Pre-installation checks

Before proceeding with installation, check the condition of the product components, suitability of the selected model and conditions of the intended installation environment:

- Check that all the materials are in good working order and suited to the intended use.
- Check that all conditions of use fall within the “application limits” of the product (paragraph 6.2) and the value limits shown in the “Product technical characteristics”.
- Check that the installation location is compatible with the overall dimensions of the product (**Fig. 9**).
- Check that the surface chosen for installing the product is solid and can ensure stable attachment.
- Make sure that the installation area is not subject to flooding; if necessary, the product may be installed, appropriately raised above ground level.
- Check that the space around the product allows safe and easy access.
- Check that all electrical cables to be used belong to the type listed in Table 1.
- Check that the automation has mechanical stops in both the opening and closing phases.

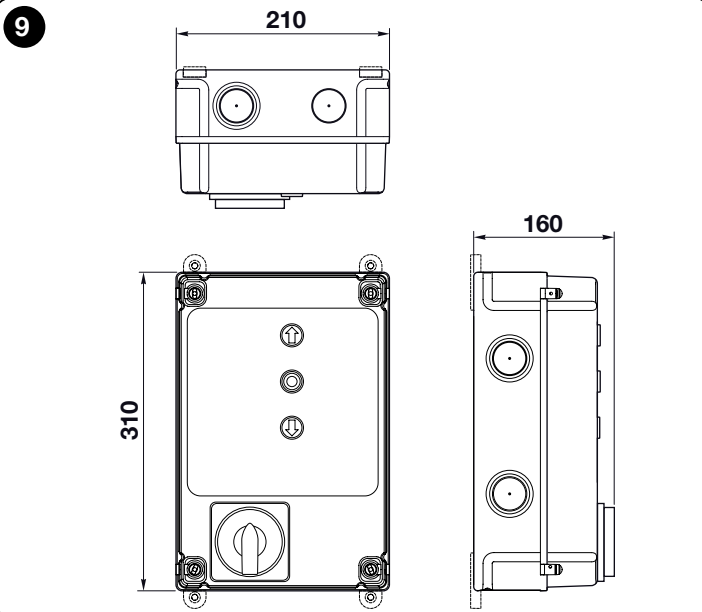

### 6.2 - Product application limits

The product is only to be used as indicated in the following table:

Control unit power supply	Type of motor*
Three-phase 3x400 Vac - 50/60Hz	Three-phase 3x400 V AC – 50/60 Hz – with Nice encoder or mechanical limit switches
Single-phase 1x230 Vac - 50/60Hz	Single-phase 1x230 V AC – 50/60 Hz – with Nice encoder or mechanical limit switches

(\* In respect of the corresponding application limits.

For single-phase motors, see Paragraph 7.2.

**⚠ CAUTION! – The control unit described in this instruction manual cannot be used in areas subject to the risk of explosion.**

**Important** – Before installation, prepare the electrical cables required for the system, by referring to “Table 1 - Technical specifications of electrical cables”.

**⚠ Caution!** – When laying the ducting for routing the electrical cables and for the cable entry point into the control unit housing, be aware that due to possible deposits of water in the junction wells, the connection ducts might create condensate in the control unit, with consequent damage to the electronic circuits.

### 6.3 - Installation of the control unit

Proceed as follows when installing the control unit:

- 01. Open the control unit box:** unscrew the screws as shown in **Fig. 10-A / Fig. 10-B**;
- 02.** Prepare the holes for routing the electrical cables for the accessories providing control and/or signalling functions. For this purpose, we recommend using a special tool (e.g. hole cutter) on the marked positions at the bottom of the box, also to ensure maintaining the level of IP protection. If necessary, you can use the lateral cable entry points, but only by using suitable ducting connections;

**TABLE 1 - Technical specifications of electrical cables**

Connection	Cable type	Maximum admissible length
CONTROL UNIT POWER SUPPLY Cable - three-phase - single-phase	4 x 1 mm <sup>2</sup> 3 x 0,75 mm <sup>2</sup>	5 m ( <b>note 1</b> ) 2 m ( <b>note 1</b> )
MOTOR cable	special cables for Nice gearmotors are on sale as accessories. for other brands, contact the motor manufacturer	5 - 7 - 11 m
Cable for FLASHING LIGHT with aerial	2 x 1 mm <sup>2</sup> (for 230 V AC flashing light) RG58 type shielded cable (aerial)	10 m
PHOTOCELL cable	4 x 0,5 mm <sup>2</sup>	10 m
KEY SWITCH cable	2 cables 2 x 0.25 mm <sup>2</sup>	10 m ( <b>note 2</b> )
SPIRAL cable for safety edge	Nice spiral cable is available as an accessory	50 m

**Note 1** – If the power cable exceeds the maximum allowed length, a cable with larger cross-section must be used

**Note 2** – These two cables may be replaced by a single 4 x 0.5 mm<sup>2</sup> cable.

**CAUTION! – The cables used must be suited to the type of environment of the installation site.**

03. At this point, you can make all the electrical connections: see Chapter 7.

To install the other devices used on the automated system, refer to the respective instruction manuals.

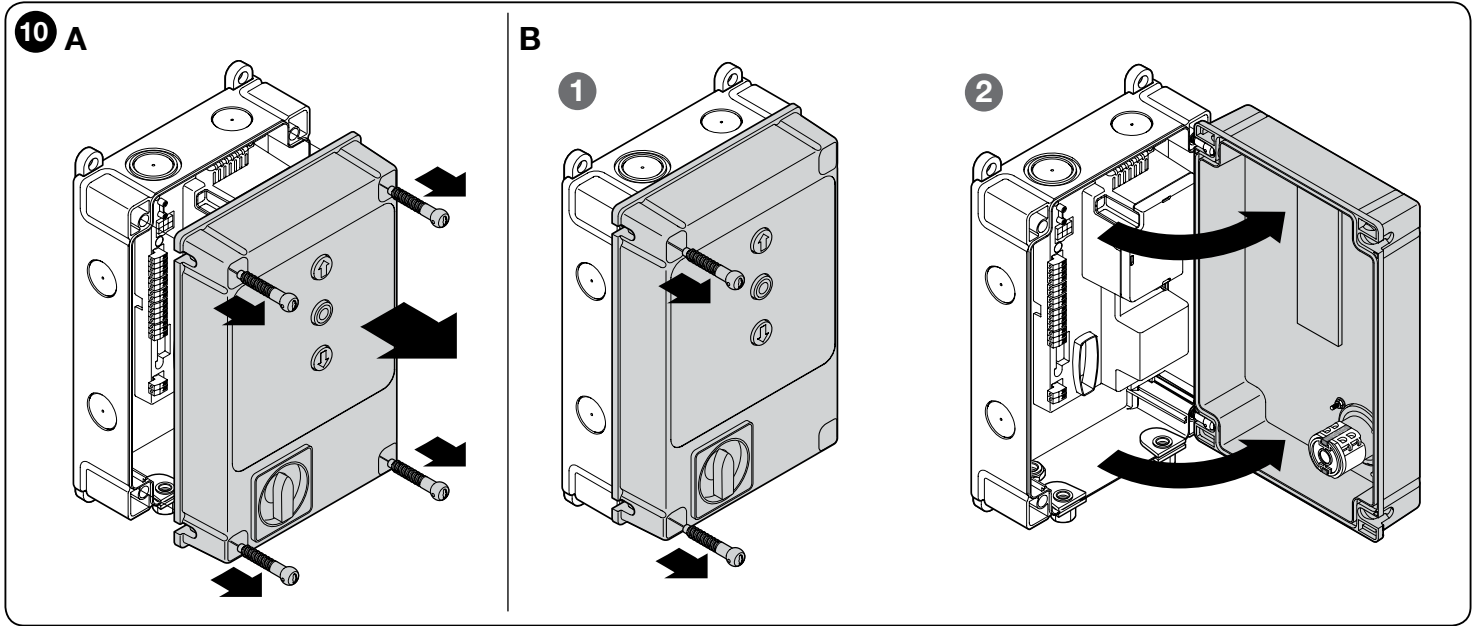

## 7 ELECTRICAL CONNECTIONS

### CAUTION!

- Before you proceed to make any electrical connections make sure that the power supply is disconnected;
- Connections must only be carried out by qualified personnel.
- You must put a device on the electricity supply line that ensures complete disconnection of the automated mechanism from the mains supply. The disconnection device must have contacts with an opening distance large enough to permit complete disconnection under the conditions sanctioned by overvoltage category III, in accordance with installation regulations. The device ensures quick, safe disconnection from the power supply if needed, and must therefore be in a position that is visible from the automation mechanism. If, on the other hand, it is located in a position which is not visible, there must be a system for preventing accidental or unauthorised reconnection to the mains supply to prevent this risk. The disconnection device is not supplied with the product.

### – Selecting the power supply voltage:

The control unit can function correctly with three-phase or single-phase power (see wiring diagrams), with either 400 V or 230 V voltage.

The default setting is three-phase 400 V power supply voltage.

To select the 230 V single-phase power supply, observe the instructions specified in Chapter 7.2

### 7.1 - Connecting the three-phase power supply cable

To make the electrical connection refer to Fig. 11.

A 16 A CEE plug must be connected to terminals L1, L2 and L3 and to the PE terminal.

### 7.2 - Connecting the single-phase power supply cable

To make the electrical connection refer to Fig. 12.

A Schuko plug must be connected to terminals L1 and L3 and to the PE terminal.

### 7.3 - Changing the power supply through the jumper

The power supply to the control unit can be changed through the jumper, as explained below (Fig. 13)

01. Remove the top cover
02. Extract the jumper (default position 3 x 400 V) using needle-nose pliers
03. Insert the jumper (1 x 230 V)
04. Re-insert the top cover

### 7.4 - Description of the electrical connections (Fig. 14): power supply, safety and control devices and accessories

You can connect control devices with “Normally Open” (NO) or “Normally Closed” (NC) contacts to the 8, 9, 10 and 11 inputs. You can then make use of one of these inputs or a combination thereof, as well as the STOP/ALT inputs if

appropriate, to connect an external push button panel, for example, or a switch with a rope connected to the ceiling.

**PUSH BUTTONS** - Input for connecting the push button panel on the cover of the box.

**ENCODER** - Input for connecting the wiring of the electronic limit switch (Nice encoder). Not usable in this version.

**COMMON (8)** - 24 V DC input that acts as a common input for the OPEN, CLOSE and ING1 inputs and positive for power supply to the services.

**OPEN (9)** - Input for devices which control only the opening movement. It is possible to connect contacts of the “Normally Open” type to this input.

**CLOSE (10)** - Input for devices which control only the closing movement. It is possible to connect contacts of the “Normally Open” type to this input.

**ING1-photo- (11)** - Normally Closed (NC) input for devices that control the movement of the automation. If this input is properly programmed with the Nice Oview programmer, you can get the following operating modes:

- Step-by-step
- Partial Open
- Open
- Close
- Photo (default)
- Photo 1
- Alt in opening
- Alt in closing

For a description and instructions on how to program the available functions, refer to the Oview function sheets for DPRO500.

**ALT** - Input for devices that stop a manoeuvre when in progress; connect contacts of the “Normally Closed” type.

**SAFE** - Input for connecting the thermal protection device of the motor.  
**CAUTION!** - It is only used for motors with mechanical limit switches. Leave “unconnected” with motors which have electronic limit switches.

**LIMIT SWITCH** - Input for connecting mechanical limit switches.

- (1) limit switch common
- (2) limit switch open
- (3) pre-limit switch close
- (4) limit switch close

**STOP** - Input for connecting resistive sensitive edges (8k2) or optical sensitive edges (OSE), as described below (Fig. 15):

OSE Connection:

- 5 → positive 12 V DC (+) (brown wires)
- 6 → signal (S) (green wires)
- 7 → GND negative (-) (white wires)

8k2 Connection:

- Connect the 8.2 kΩ resistor between terminals 6 (signal - S) and 7 (negative - GND)

**IBT4N** - Input for connecting the Oview programmer, with the IBT4N adapter. **CAUTION** - disconnect the power supply before connecting/disconnecting the programmer.

**ANTENNA**  - Input for connecting the radio receiver aerial (Note: the aerial is built into the Nice LUCY B, MBL and MLBT flashing lights).

**OUT (CONNECTOR FOR NDA040)** - Connector for NDA040 accessory card that adds two outputs to voltage-free contacts. These outputs can be properly programmed with the Nice Oview programmer. For a description and instructions on programming the available functions, see the NDA040 accessory board manual.

**MOTOR** - Output for connecting the single-phase and three-phase motor.

For single-phase motors:

U - common

V - opens

W - closes

**LINE** - Input for connecting the power supply.

L1-L2-L3: THREE-PHASE connection

L1-L3: SINGLE-PHASE connection

 **PE** - Input for the earth connection for the control unit and motors.

## IMPORTANT!

**We DO NOT recommend that you connect any device or accessory not mentioned in this instruction manual.**

**The manufacturer declines all responsibility whatsoever for any damage due to improper use of the various system devices that does not comply with the instructions in this manual.**

**For more information, please contact the Nice Customer Service.**

### 7.5 - Electrical connections of the control unit



**CAUTION!** – Before you proceed to make any electrical connections make sure that the mains power supply is disconnected.

After attaching the control unit box and preparing the holes for routing the electrical cables (see paragraph 6.3), make the electrical connections as follows:

- 01.** First connect the power supply cable:
  - for the **three-phase** line see Paragraph 7.1 and **Fig. 11**
  - for the **single-phase** line see Paragraph 7.2 and **Fig. 12**
- 02.** Then, connect the power supply cable from the motor:
  - Motor with mechanical limit switch (**Fig. 16**)
- 03.** Lastly, connect the electrical cables of the various available accessories, referring to **Fig. 13** and paragraph 7.3.

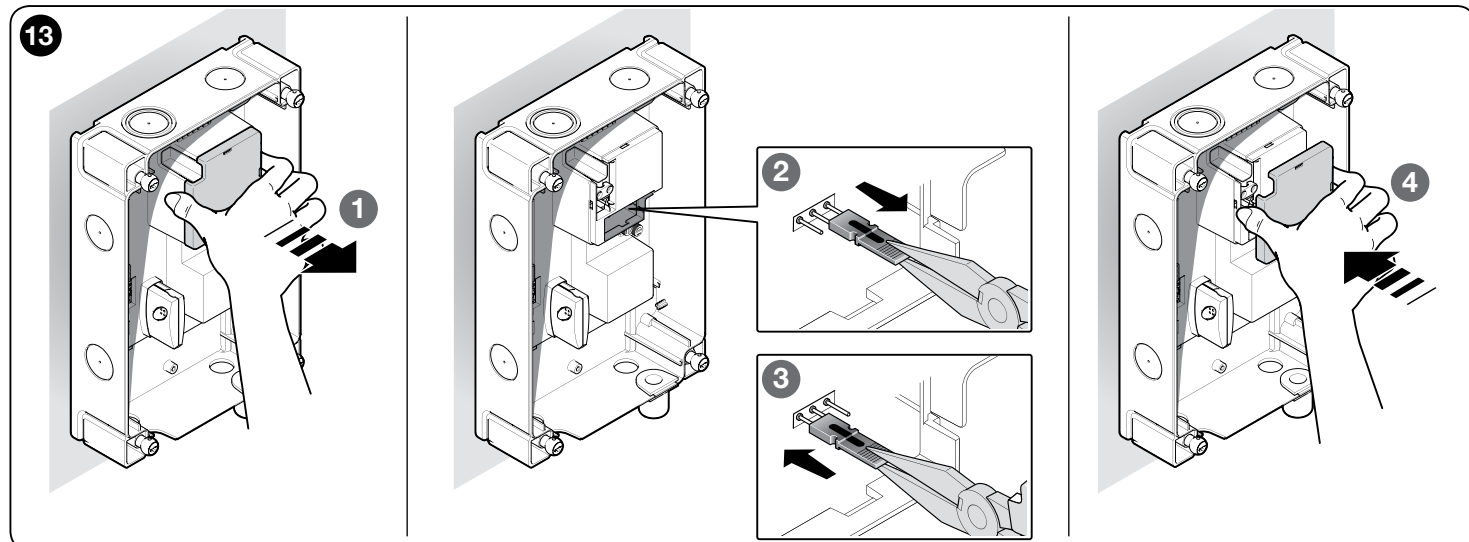
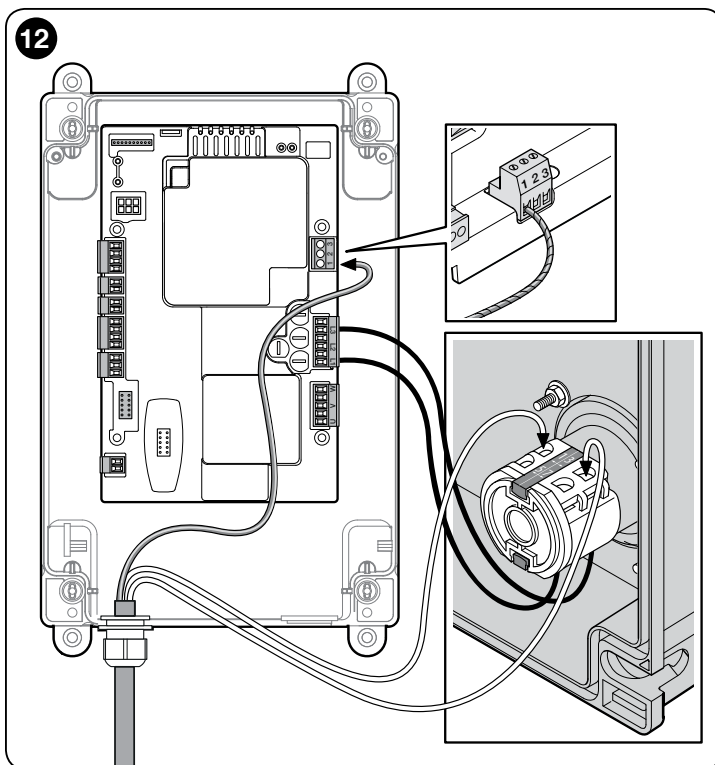
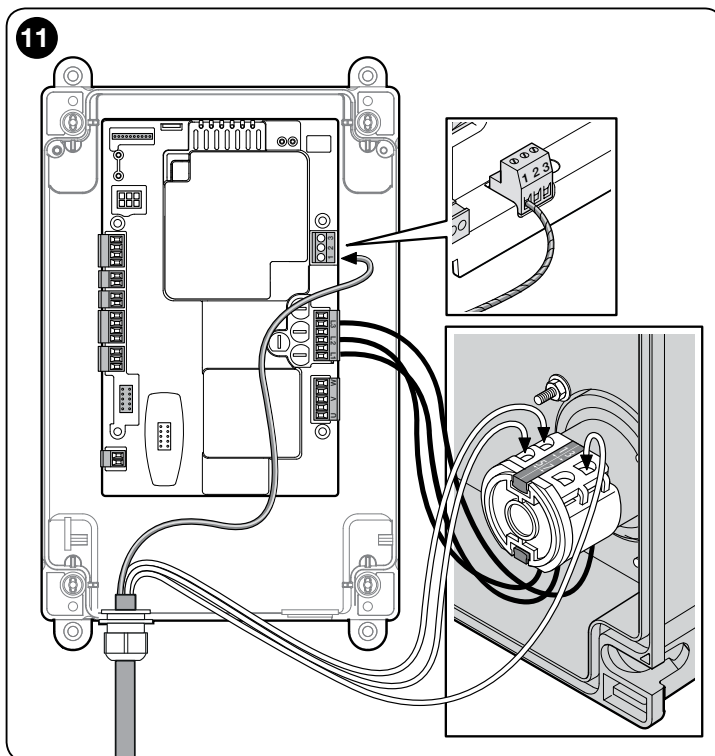
*Note – To facilitate connecting the cables, you can remove the terminals from their positions.*



<b>LED SAFETY</b>	= safety chain LED
<b>LED L2</b>	= OK LED (green)
<b>LED L1</b>	= Warning LED (red)
<b>OUT</b>	= slot for the NDA040 accessory board for expanding outputs
<b>PROG</b>	= DIP switch for programming
<b>ENCODER</b>	= electronic limit switch
<b>INPUT</b>	external inputs 8 - com (+24 V DC common) 9 - open 10 - close 11 - photo (ing1)
<b>ALT</b>	= ALT terminal
<b>SAFE</b>	= only for motors with mechanical limit switches (leave unconnected with motors which have electronic limit switches)
<b>LIMIT SWITCH</b>	= mechanical limit switch
<b>STOP</b>	STOP terminal used for 8K2 safety edge or OSE 5 - positive (+) safety edge 6 - safety edge signal 7 - negative GND (-)
<b>IBT4N</b>	= IBT4N interface connector (not supplied)
<b>OXI</b>	= connector for connecting radio receivers with SM plug (SMXI/OXI)
	= aerial
	= earth connection
<b>LINE</b>	= connector for connecting the three-phase or single-phase power line
<b>FUSES</b>	= F1, F2, F3, F4: see Technical Specifications
<b>MOTOR</b>	= motor

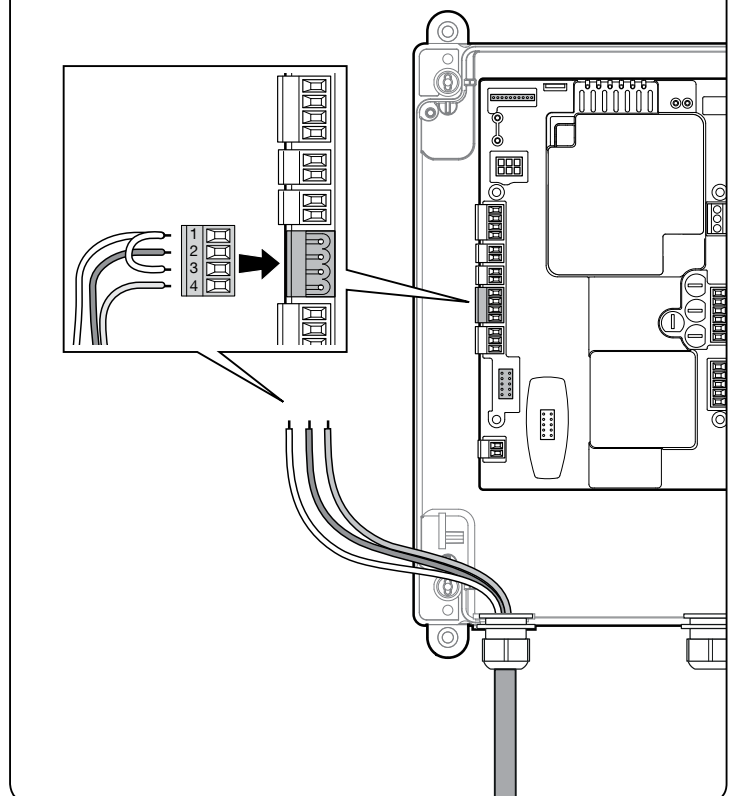
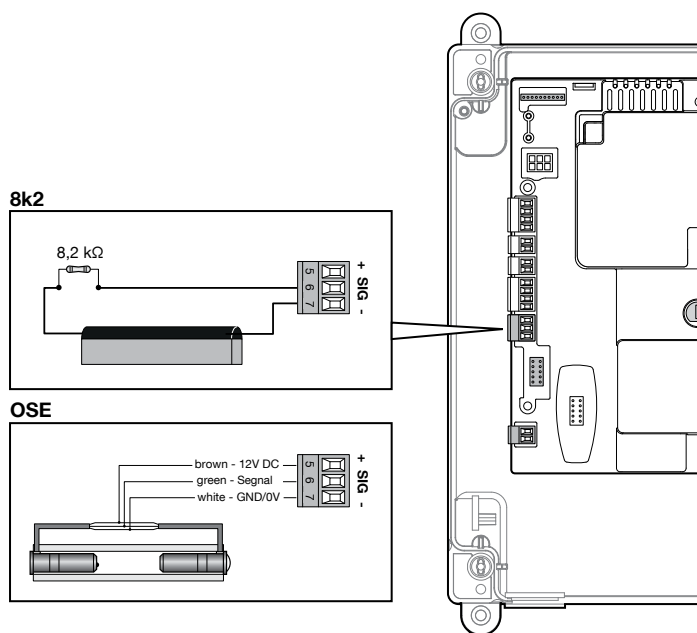
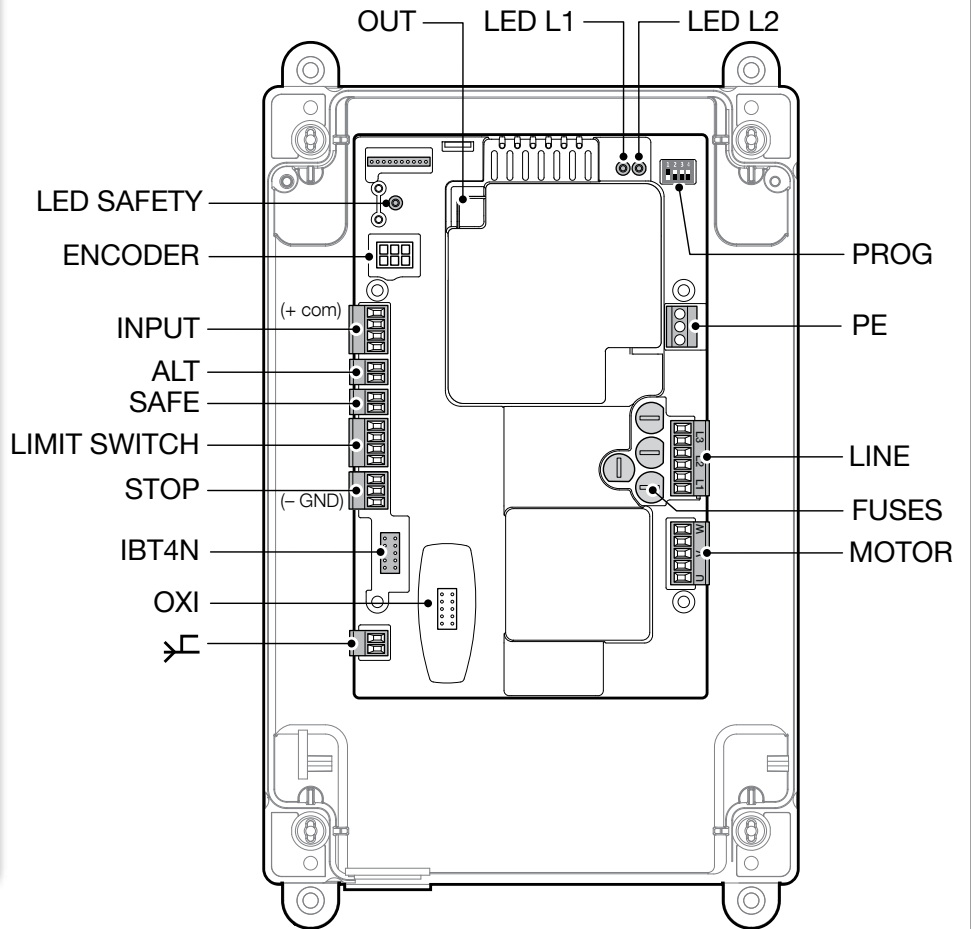



## 7.6 - STOP SAFETY EDGE Input

The function of the SAFETY EDGE input is to cause the immediate stop of a manoeuvre when in progress followed by a short reverse manoeuvre.

This input can be connected to devices such as optical sensitive edges (OSE) or those with 8.2 kΩ constant resistance output.

During the recognition phase, the control unit recognises the type of device connected and causes a "STOP" whenever any variation in the recognised status occurs.

Multiple devices, even of different types, can be connected to the STOP SAFETY EDGE input if appropriately organised:

- NO devices: connect the 8.2 kΩ resistor in parallel to the device;
- NC devices: connect the 8.2 kΩ resistor in series to the device;
- You can connect multiple NC devices "in series" with each other without quantity limits;
- If there are multiple devices, all must be connected "in cascade" with a single 8.2 kΩ terminal resistance;
- You can also create a combination of NO and NC types, by placing the two contacts "in parallel". In this case, you need to place a 8.2 kΩ resistance "in series" with the NC contact; this also makes it possible to put three devices together: NO, NC and 8.2 kΩ.

## 7.7 - Connecting a radio receiver

The control unit has an SM connector for connecting an SMXI, SMXIS, OXI, OXIT or similar radio receiver (optional accessory, not supplied).

To connect the radio receiver, you must disconnect the mains power supply from the control unit and insert the receiver as shown in **Fig. 17**.

Table 2 shows the actions performed by the control unit according to the activated outputs or the commands sent by the radio receiver.

*Note - For further information, refer to the instruction manual for the receiver.*

**TABLE 2**

SMXI, SMXIS Receiver in "Mode 1 or 2"	
output	description
Output No. 1	Step-by-Step
Output No. 2	Partial open; <u>factory setting</u> : it opens to halfway (this may be changed during the position acquisition phase or by using the Oview programmer)
Output No. 3	Open
Output No. 4	Close
OXI, OXIT receiver programmed in "extended Mode 2"	
command	description
Command No. 1	Step-by-Step
Command No. 2	Partial open; <u>factory setting</u> : it opens to halfway (this may be changed during the position acquisition phase or by using the Oview programmer)
Command No. 3	Open
Command No. 4	Close
Command No. 5	Stop
Command No. 6	Step-by-Step Condominium
Command No. 7	Step-by-Step High priority
Command No. 8	Partial open 2
Command No. 9	Partial open 3
Command No. 10	Open and Lock automation
Command No. 11	Close and Lock automation
Command No. 12	Lock automation
Command No. 13	Release automation
Command No. 14	Timed Courtesy light
Command No. 15	Courtesy light ON/OFF

## 7.8 - Initial startup and electrical connections test

After supplying power to the control unit, carry out the following checks:

- Verify that the green L2 LED (close to the DIP switches) flashes regularly, with a frequency of 1 flash per second.
- If the system is equipped with photocells, check that their LEDs flash correctly (RX); the type of flashing is not significant because that depends on other factors.
- Ensure that the red SAFETY LED near the keyboard cable connector is permanently ON (see Safety LED Diagnostics table, Paragraph 10.2).

If any one of these tests fails to comply with requirements, you must disconnect the electrical power from the control unit and check the various electrical connections made previously.

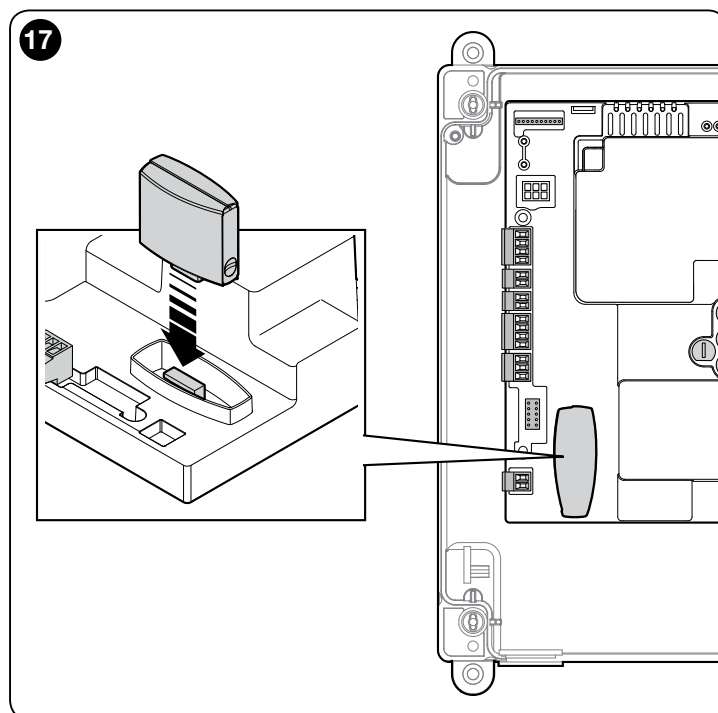

## 7.9 - Total deletion of the control unit memory

You can delete all the data stored on the control unit and restore it to its original state with the default settings.

01. Set dip switches 1-2-3-4 to ON = the red and green leds start flashing quickly
02. Press and hold the STOP button for 3 sec. until the green and red leds remain lit
03. Release the STOP button
04. At this point the control unit performs a RESET = the red and green leds start flashing quickly
05. Set dip switches 1-2-3-4 to OFF

## 7.10 - Recognition of the safety devices and the Opening and Closing positions

After performing the initial startup (paragraph 7.8) and before setting the gate Opening and Closing positions, you must have the control unit run the recognition phase of the connected safety devices on the "STOP Safety Edge" input.

**CAUTION!** - During the recognition phase, at least one safety device must be connected to the control unit.

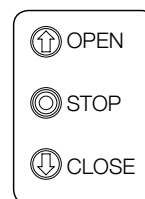

01. Set dip switch 1 to ON =  
 - Green LED begins to flash rapidly  
 - Red LED is OFF
02. Press and hold the STOP button until the red led comes on and remains lit (after about 3 sec.)

03. Release the STOP button

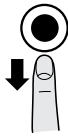

This procedure must be repeated if a modification is made to the devices connected to the "STOP Safety Edge" terminal (for example, after connecting a new device to the control unit).

After performing the recognition of the safety devices on the automated system, the control unit must recognise the gate Opening and Closing positions.

**CAUTION!** - The recognition procedure of the safety devices and the gate Opening and Closing positions must be done consecutively, without interruption. You can not perform the recognition of the safety devices at one time and the recognition of the positions at another time.

7.10.1 - Recognition of the Opening and Closing positions with mechanical limit switch

You can program 2 positions, as follows:

Position	Meaning
Opening	Maximum opening position. When the gate reaches this position it stops.
Closing	Maximum closing position. When the gate reaches this position it stops.

**Caution!** - If the direction of rotation does not correspond to the direction set (Open button = opening direction), you need to invert the "V" and "W" connections (phase inversion) in the motor connector (Fig. 18).

To perform the procedure, proceed as follows:

01. Move DIP switch 1 to OFF

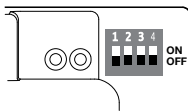

02. Press the "Open" button to move the gate to its maximum open position

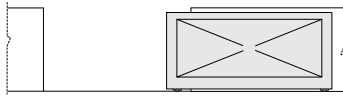

03. Press the "Close" button to move the gate to its maximum closed position

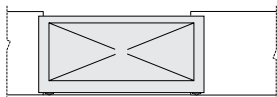

**CAUTION!** - The recognition phases must not be interrupted. If there is an interruption, you must repeat the entire recognition process. If at the end of the recognition phase, the red LED flashes 9 times-pause-9 times, it means that an error has occurred.

If instead it flashes 3 times-pause-3 times, reset the error by pressing the STOP button and invert the opening limit switch connection with that of the closing limit switch at the LIMIT SWITCH terminal (Fig. 14). The position recognition phase can be repeated at any time, also after the installation.

7.11 - Operating modes

**CAUTION!** - If the functions of Table 3 are programmed with the Oview programming unit, it is necessary to set the dip switches to OFF.

TABLE 3

DIP1	DIP2	DIP3	DIP4	Function
OFF	OFF	OFF	OFF	Hold-to-run movement
ON	x	OFF	OFF	Acquisition of positions and status of the ALT input
OFF	ON	OFF	OFF	Rotation direction of the encoder reversed
OFF	x	OFF	ON	Industrial mode (semi-automatic opening - hold-to-run closing), if positions recognised
OFF	x	ON	OFF	Semi-automatic mode, if positions recognised
OFF	x	ON	ON	Automatic mode with adjustable pause time, if positions recognised (see para. 10.1.2 "Other functions" for info on saving the pause time)

18

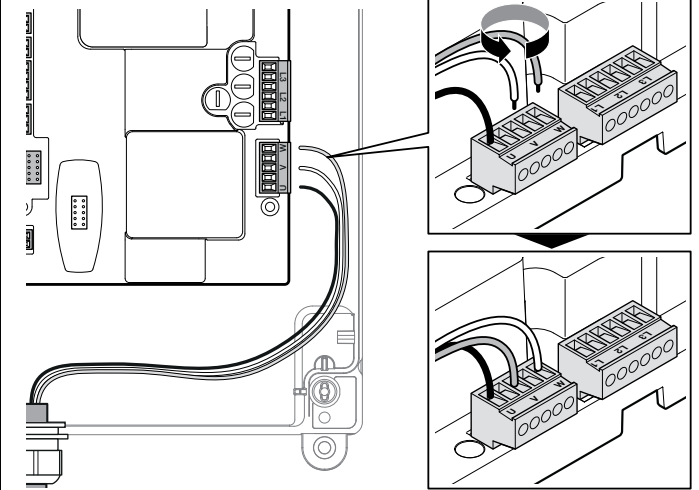

7.12 - Oview programming unit

Using the Oview programming unit allows you to manage the installation, maintenance and diagnosis of the entire automated system in a thorough and rapid manner.

You can connect Oview to the control unit via the IBT4N interface using a bus cable with 4 wires inside.

To access the BusT4 connector, you need to open the control unit box, plug the IBT4N connector into the appropriate slot and then connect the Oview programmer (Fig. 19).

Oview can be used at a maximum cable distance of 100 metres from the control unit; it can be connected simultaneously to multiple control units (up to 16) and can remain connected even during normal operation of the automated system. When working with Oview, it is very important to observe the instructions in the Oview instruction manual.

If there is an OXI radio receiver in the control unit, when you use Oview you can have access to the parameters of the transmitters memorised in the receiver. For further information, refer to the Oview instruction manual or the control unit function sheet available from the website [www.niceforyou.com](http://www.niceforyou.com)

**CAUTION!** - If the functions of Table 3 are programmed with the Oview programming unit, it is necessary to set the dip switches to OFF.

19

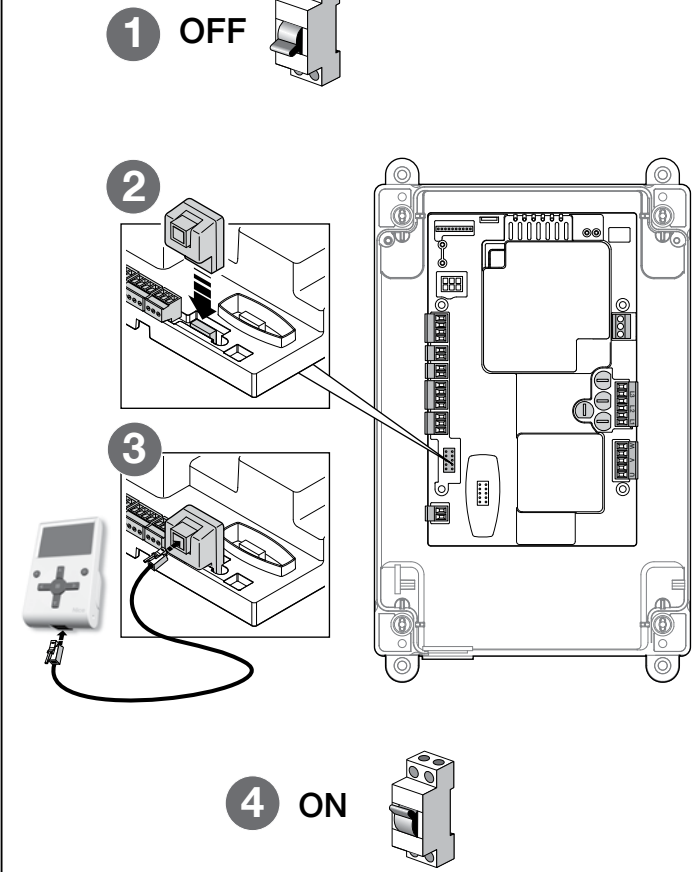

## 8 TESTING AND COMMISSIONING

The testing and commissioning phases are the most important when creating an automated system in order to ensure maximum safety. The testing procedure can also be performed as a periodic check of the automation devices.

These phases must be performed by qualified and experienced personnel who must take charge of establishing the tests necessary to verify the solutions adopted in respect of risks and verify the compliance of the system with applicable standards, legislation and regulations, in particular all requirements of the standard EN 12445 which establishes the test methods for checking automated systems for doors and gates. The additional devices must undergo specific testing, both in terms of their functions and in terms of their interaction with the control unit; therefore, you need to refer to the instruction manuals for the individual devices.

### 8.1 - Testing

The sequence of steps to be performed when running the testing phase, as described below, refers to a typical system:

- 1 Check that all the instructions in the "Installation warnings" chapter have been rigorously complied with.
- 2 Release the motor. Check that the gate can be manually manoeuvred with a force no greater than 225N.
- 3 Lock the motor.
- 4 Using the control devices (transmitter, push button, key switch, etc.), test the Opening, Closing and Stopping of the gate, ensuring that the movement of the gate leaves corresponds to specifications. Test several times to assess the movement of the gate and check for any defects in assembly or adjustment and for any particular points of friction.
- 5 Check, one by one, that all the safety devices featured in the system (photo-cells, sensitive edges, etc.) work properly.
- 6 If the dangerous situations caused by the movement of the gate leaves have been safeguarded against by limiting the impact force, the impact force must be measured according to the EN 12445 standard.

### 8.2 - Commissioning

Commissioning can only be performed after obtaining positive results in all the test phases run on the control unit and the other devices (paragraph 8.1). **It is not permissible to execute partial commissioning or to enable use of the system in "makeshift" conditions.**

- 1 Prepare and store the technical documentation for the automated system for at least 10 years. This must include at least: an assembly drawing of the automated system, a wiring diagram, an analysis of hazards and solutions adopted, a manufacturer's declaration of conformity of all the devices installed (for the control unit, use the annexed CE declaration of conformity); a copy of the automation system instruction manual and maintenance schedule.
- 2 Post a label on the gate providing at least the following data: type of automated system, name and address of manufacturer (person responsible for the "commissioning"), serial number, year of manufacture and "CE" marking.
- 3 Post a permanent label or sign near the gate detailing the operations for releasing the system and its manual operation
- 4 Post a permanent label or sign on the gate containing this picture (min. height 60 mm).

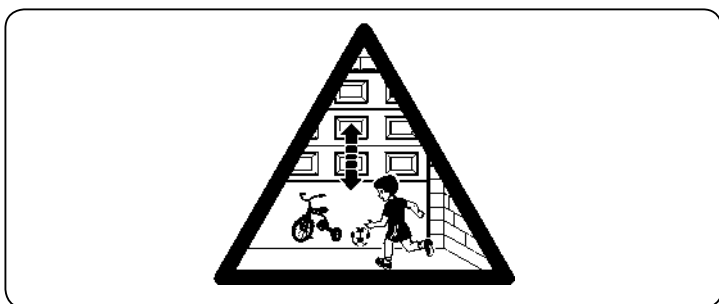

- 5 Prepare the declaration of conformity for the automation system and hand it to the owner.
- 6 Prepare the "Instructions and warnings for the use of the automation system" and hand it to the owner.
- 7 Prepare the maintenance schedule for the automation system and hand it to the owner; it must include all the instructions regarding maintenance of the individual devices.

## 9 INSTALLATION AND ELECTRICAL CONNECTION OF TWO CONTROL UNITS FOR LEAVES MOVING IN OPPOSITE DIRECTIONS

To create an automation consisting of two leaves moving in opposite directions, it is necessary to use two control units connected as shown in **Fig. 20**.

The motors and limit switches must be connected to each control unit. The warning light and the G.O.I. (Gate Open Indicator) can be connected to any one of the two control units, or can be installed one on each control unit (**Fig. A** page 6).

The inputs must be placed parallel to one another; the "Common" input can be connected to either one of the two control units.

Connect in parallel safety edge (8k2/OSE) "-" connectors of both control units. Configure the "Open" input as "Condominium" using the O-View programmer, which allows for synchronising the leaves should the two control units lose their synchronisation.

With this configuration it is important to remember that:

- the intervention of the sensitive edge only impacts the single leaf;
- the red STOP key only impacts the single leaf;
- the intervention of the thermal protection device only impacts the single leaf.

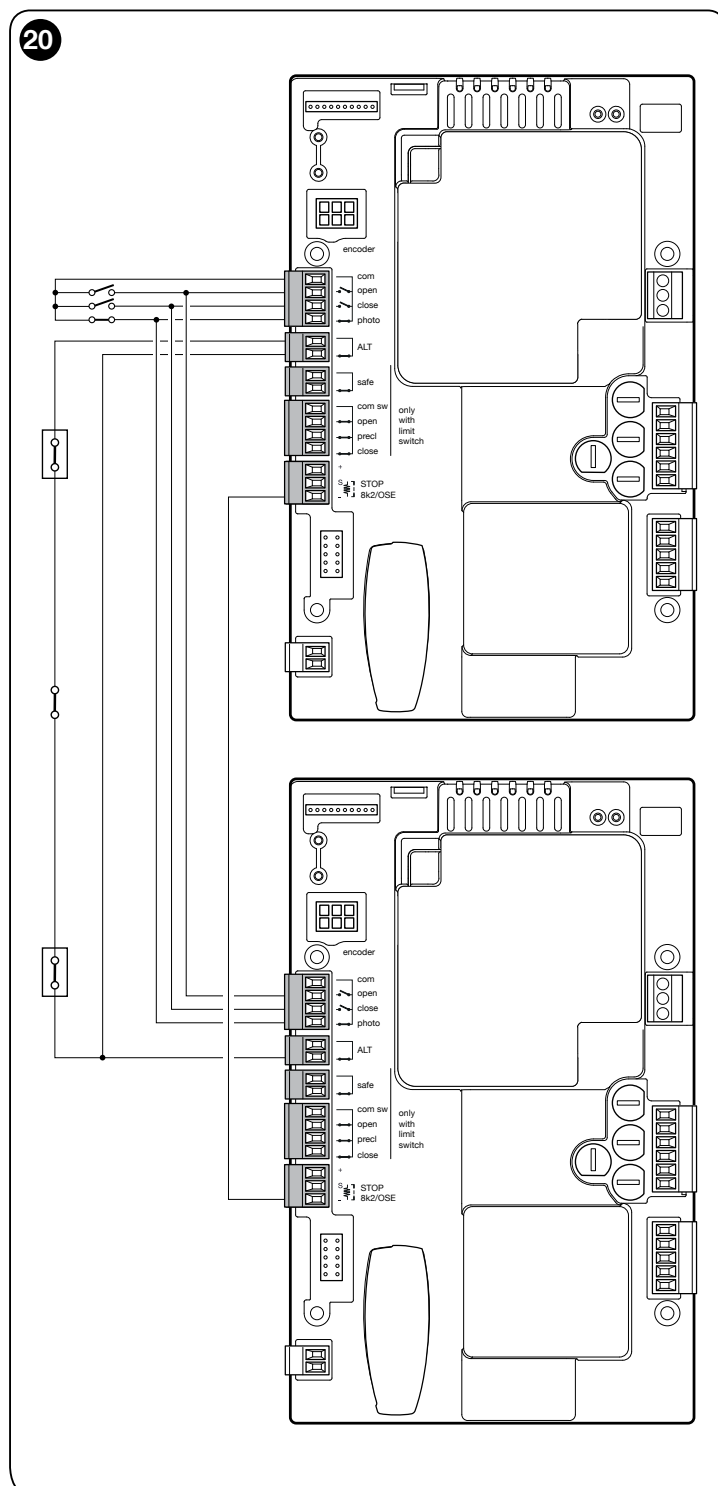



## 10.1 - Further details

### 10.1.1 - Signals when switching ON

When the DPRO500 control unit is switched ON, the reaction of the green OK L2 led and the red WARNING L1 LED is important, as shown in Table 4. In particular, it indicates whether:

- The recognition of the Opening and Closing positions is correct;
- The recognition of the (sensitive edge) safety device is correct and what kind of safety device has been recognised.

Signals when switched on	Signal	
	GREEN OK L2 LED	RED WARNING L1 LED
Blank memory (no acquired position or safety device)	Rapid flashing for 5 seconds	Rapid flashing for 5 seconds
Positions acquired correctly and "8k2" safety recognised	Rapid flashing for 2 seconds	Just one slow flash
Positions acquired correctly and "OSE" safety device recognised	Rapid flashing for 2 seconds	Two slow flashes

After providing the signals shown in Table 4, the DPRO500 control unit shows any errors through Diagnostics using the OK L2 led and the WARNING L1 LED.

### 10.1.2 - Other functions

#### Status and diagnostics indicator (terminal on the keyboard)

The control unit allows you to connect a 24V-5W max. indicator light to the "indicator" terminal on the push button panel housed inside the box cover (Fig. 21: terminal 1 -, 2 +). The "indicator" can be installed on the cover itself, by making a hole on the latter, or it can be installed outside the control unit at a maximum distance of 2 m from the latter.

### CAUTION! - The output is not protected against short-circuits.

This "indicator" functions in the following way:

- off when the safety chain is open (ALT inp, red STOP button, thermal protection or release)
- flashes 0.5 s ON, 0.5 s OFF when it works properly
- shows the same diagnostics as the red L1 WARNING LED when there are "serious errors" (Paragraph 10.2).

#### Setting the pause time for automatic closing

1 Set DIP switches 3 and 4 to ON.

2 Send a command to open the gate so as to move the gate to its fully open position.

3 Once this position is reached, wait for a period of time equal to the required pause time for automatic closing and then command the gate to close. The pause time for automatic closing is now saved.

In order to change the pause time, set dip 3 and 4 to OFF and then back to ON. At this point you must repeat the sequence of opening, pause time and closing.

**CAUTION!** - When DIP switch 4 is moved to the OFF position, the pause time is deleted.

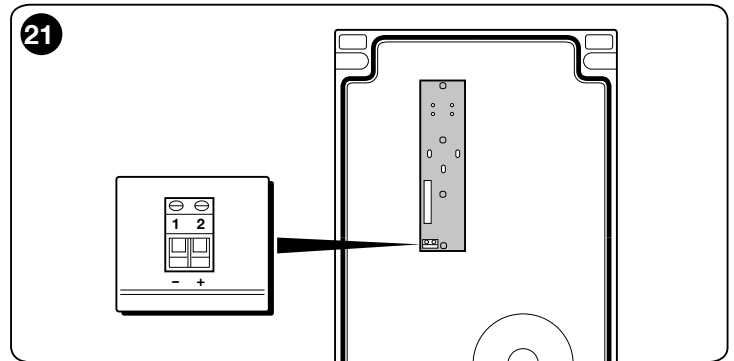

## 10.2 - Diagnostics

Some devices are equipped to display messages to identify their status and faults. The following table describes the various alarm signals according to the type of problem. These alarm signals are provided by appropriate flashes of the green OK L2 LED and the red WARNING L1 LED and from the flashing light (if there is one) connected to the specially programmed control unit outputs.

DIAGNOSTICS GREEN OK L2 LED			
Signal	Cause	Solution	Flashing light
2 flashes - short pause 2 flashes - long pause	Triggering of a photocell	At the start of the manoeuvre, one or more photocells fail to give the enable signal; check for obstacles and whether the photocells are interfering with each other's IR. When the safety devices have intervened, the automation can be controlled with a person present through the wired controls. It is not possible to send commands via radio.	Flash
4 flashes - short pause 4 flashes - long pause	Triggering of the STOP input	At the start of or during the manoeuvre, the STOP or ALT input was triggered; identify the cause. When the safety devices have intervened, the automation can be controlled with a person present through the wired controls. It is not possible to send commands via radio.	Flash
6 flashes - short pause 6 flashes - long pause	Manoeuvre limiting device	---	Flash
9 flashes - short pause 9 flashes - long pause	Automation system locked	Send the "Release Automation" command or command the manoeuvre with "Step-by-Step High Priority".	Flash
The LEDs come on for 3 seconds	Lock automation	---	Flash
2 flashes of 1 second with pause of 1.5 seconds	Automation system released	---	Flash

DIAGNOSTICS RED WARNING L1 LED			
⚠ Certain signals can be cancelled by pressing the red STOP button			
Signal	Cause	Solution	Flashing light
5 flashes - short pause 5 flashes - long pause	EEPROM error - Error in the internal parameters of the control unit	Disconnect and reconnect the power supply. If the error persists, run the "Total deletion of the control unit memory" (paragraph 7.8) and rerun installation. If the condition persists, there may be a serious fault and you will need to replace the electronic circuit board.	Flash
2 flashes - short pause 2 flashes - long pause	Safety Test Error	Rerun the recognition procedure for the safety devices connected to the control unit (paragraph 7.9).	---
3 flashes - short pause 3 flashes - long pause	Error in direction of rotation of the Encoder Or inverted limit switch	Reverse the direction of rotation of the encoder by moving DIP switch 2 to ON (see paragraph 7.10). If the motor mounts a mechanical limit switch, reset the error by pressing the STOP button and invert the opening limit switch connection with that of the closing limit switch at the LIMIT SWITCH terminal (Fig. 14).	---

4 flashes - short pause 4 flashes - long pause	Error with safety limit switches	The gate has gone past the safety limit switches during Opening or Closing. Move the gate manually to about half way up using the emergency manoeuvre system (see the manual of the motor) and press the STOP button on the cover in order to restore operation. Assess whether you need to change the previously acquired Opening/Closing positions.	---
6 flashes - short pause 6 flashes - long pause	Error with contactor	Disconnect all the power lines for a few seconds, then try sending a command again; if the problem persists, there may be a serious fault on the circuit board or on the connections of the motor. Carry out checks and replace parts, if required.	---
7 flashes - short pause 7 flashes - long pause	RS485 communication error on Encoder	Check that the motor-control unit cable is connected correctly, in particular the encoder cable (6 coloured wires).	---
8 flashes - short pause 8 flashes - long pause	Encoder error	Check that the motor-control unit cable is connected correctly, in particular the encoder cable (6 coloured wires). Rerun the recognition procedure of the Opening and Closing positions.	---
9 flashes - short pause 9 flashes - long pause	Error in limit switch acquisition	Repeat the recognition procedure of the Opening and Closing positions.	---
10 flashes - short pause 10 flashes - long pause	Error in movement time-out	The default setting for the movement time-out is 60 seconds. Check whether there are any obstructions to the movement of the gate or whether the gate has actually performed the movement. Check whether the duration of the timer has been changed (using the Oview programmer if available). Repeat the recognition of the Opening and Closing positions.	---

**Note - The diagnostic signals provided by flashing leds stop when the control unit is given a command.**

**By using an external flashing light\*, the diagnostics signals continue for two sequences of flashes (e.g. "3 flashes – short pause – 3 flashes – long pause" repeated twice).**

**IMPORTANT: To connect the external flashing light, you need to use the additional NDA040 board (not supplied).**

**\* Configured with the Oview programmer as "Flashing Light 1"**

L1 and L2 LED DIAGNOSTICS	
Signal	Cause
Flashes fast alternating red LED and green LED	Firmware updating phase in progress
4 flashes - pause - 4 flashes of the LED simultaneously	Awaiting firmware updating

SAFETY LED DIAGNOSTICS		
Signal	Cause	Solution
On	Correct operation	---
Off	Safety chain open	The safety chain is made up of the series of inputs (ALT, Stop via button, motor thermal protection, motor release). Close the circuit

## 11 WHAT TO DO IF...

### (troubleshooting guide)

The following is a list of possible malfunctions that may occur during installation or due to a failure, together with the possible solutions:

- **The motor is at a standstill, no manoeuvre is commanded and the red LED flashes:** verify the type of flashing by checking the L1 LED Diagnostics table (paragraph 10.2) and press the red STOP button to cancel the diagnostics.
- **The radio transmitter does not control movements and the LED on the transmitter does not come ON:** check to see if the transmitter batteries have run down and replace them, if necessary.
- **The radio transmitter does not control movements but the LED on the transmitter comes ON:** check to see if the transmitter is correctly saved on the radio receiver. Also, check that the transmitter sends its radio signals correctly, by performing the following empirical test: press any button on the transmitter and place its LED on the aerial of any ordinary radio that is ON and tuned to 108.5 Mhz (or close to it) on the FM band; in this way, you should hear a slight noise with crackling pulses.
- **When a command is sent, no manoeuvre takes place and the OK LED does not flash:** check that the control unit is connected to mains supply with voltage of 230/400V. Also, check that the fuses have not blown; if they have, identify the cause of the failure and then replace them with others of the same type.
- **When a command is sent, no manoeuvre takes place and the flashing light is OFF:** check that the command is actually received; if the command reaches the SS input, the OK LED flashes twice to indicate that the command has been received.
- **The manoeuvre fails to start and the flashing light flashes a few times:** count the number of flashes and check the meaning of the flashes with the diagnostics table in paragraph 10.2
- **The motor turns in the opposite direction:**
  - for a three-phase motor, you need to invert the "V" and "W" phases of the motor
  - for a single-phase motor, you need to invert the "V" and "W" phases of the motor
- **The manoeuvre starts but stops shortly after:** identify the cause using the diagnostics of the Leds on the control unit.
- **The red WARNING L1 led flashes 9 times followed by a pause:** there was an error in the recognition procedure of the Opening and Closing positions. You must delete the memory (see 7.9) and repeat the position recognition procedure (see 7.10).

## 12 PRODUCT DISPOSAL

**This product constitutes an integral part of the automation and, therefore, must be disposed of together with it.**

Similarly to the installation phase, once the product reaches the end of its useful life, the disassembly and scrapping operations must be performed by qualified personnel.

This product is made of various types of materials, some of which can be recycled while others must be scrapped. Seek information on the recycling and disposal systems envisaged by local regulations in your area for this product category.

**CAUTION!** – Some parts of the product may contain polluting or hazardous substances which, if released into the environment, constitute serious environmental and health risks.



As indicated by the adjacent symbol, the product may not be disposed of together with domestic waste. Sort the materials for disposal, according to the methods envisaged by current legislation in your area, or return the product to the retailer when purchasing an equivalent product.

**CAUTION!** – Local legislation may include the application of heavy fines in the event of improper disposal of this product.

## 13 TECHNICAL SPECIFICATIONS

**WARNINGS:** • All technical specifications stated herein refer to an ambient temperature of 20° C (± 5° C). • Nice S.p.A. reserves the right to apply modifications to products at any time when deemed necessary, maintaining the same intended use and functionality.

<b>Type</b>	Electromechanical self-braking gear motor for the automatic movement of sliding gates for industrial use, complete with electronic control unit DPRO500
<b>Pinion</b>	Z = 18; Module = 6; Pitch = 18.8
<b>Peak thrust</b>	216 Nm
<b>Nominal torque</b>	65 Nm
<b>Nominal torque speed</b>	0.16m/s (9,50m/min)
<b>Operating limits</b>	TUB4000 is generally capable of automating gates up to 4000 Kg in weight and 30 m in length.
<b>Power supply</b>	3~ 400V ac +/-10%; 50Hz.
<b>Max. absorbed power</b>	580 W
<b>Nominal absorption</b>	1,6 A
<b>Insulation class</b>	1 (a safety earthing system is required)
<b>Operating temperature</b>	-20°C ... 55°C
<b>Protection level</b>	IP 54
<b>Dimensions (mm)</b>	580 x 480 x 240
<b>Weight</b>	60 kg

## EU Declaration of Conformity (N. 624/TUB4) and declaration of incorporation of “partly completed machinery”

**Note:** the contents of this declaration correspond to that stated in the official document filed in the offices of Nice S.p.A. and, in particular, the latest version thereof available prior to the printing of this manual. The text herein has been re-edited for editorial purposes. A copy of the original declaration can be requested from Nice S.p.A. (TV) Italy.

**Revision:** 2

**Language:** EN

**Manufacturer's name:** NICE S.p.A.

**Address:** Via Pezza Alta N°13, 31046 Rustignè di Oderzo (TV) Italy

**Person authorised to compile the technical documentation:** NICE S.p.A.

**Address:** Via Pezza Alta N°13, 31046 Rustignè di Oderzo (TV) Italy

**Product type:** Electromechanical gearmotor 400V three-phase

**Model / Type:** TUB4000

**Accessories:** Radio receivers mod. SMXI, SMXIS and ONEXI, OXI, OXIBD, OXILR, OVIEW  
Optical safety edge TMF, NDA040  
Photocells ERA family S, M, L

The undersigned, Roberto Griffa, as Chief Executive Officer, hereby declares under his own responsibility that the product identified above complies with the provisions of the following directives:

- Directive 2014/30/UE (EMC)      EN 61000-6-2:2005 - EN 61000-6-3:2007+A1:2011

In addition, the product conforms to the following directive in accordance with the provisions applicable to “partly completed machinery”:  
(Annex II, part 1, section B):

- In addition, the product conforms to the following directive in accordance with the provisions applicable to “partly completed machinery”:  
Directive 2006/42/EC OF THE EUROPEAN PARLIAMENT AND COUNCIL of May 17 2006 regarding machines and amending Directive 95/16/EC (consolidated text).
  - It is hereby declared that the relevant technical documentation has been compiled in accordance with Annex VII Part B of Directive 2006/42/EC and that the following essential requirements have been applied and fulfilled: 1.1.1- 1.1.2- 1.1.3- 1.2.1-1.2.6- 1.5.1-1.5.2- 1.5.5- 1.5.6- 1.5.7- 1.5.8- 1.5.10- 1.5.11
  - The manufacturer agrees to transmit to the national authorities any pertinent information on “partly completed machinery”, in response to a motivated request, without prejudice to its intellectual property rights.
  - Should the “partly completed machinery” be commissioned in a European country with an official language different to the one used in this declaration, a translation into that language accompanying this declaration must be provided by the importer.
  - The “partly completed machinery” may not be commissioned until the final machinery into which it is to be incorporated has been declared to conform to the provisions of Directive 2006/42/EC, where appropriate.

The product also complies with the following standards: EN 60335-1:2012+A11:2014, EN 62233:2008, EN 60335-2-103:2015

Place and Date: Oderzo, 19/12/2017

Ing. **Roberto Griffa**  
(Chief Executive Officer)

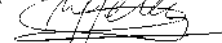

**▲ This user guide should be stored and handed to all users of the automation.**

**WARNINGS**

- **Keep at a safe distance from the moving gate until it is completely open or closed; do not transit through the gate until it is completely open and has come to a standstill.**
- **Do not let children play near the gate or with its commands.**
- **Keep the transmitters away from children.**
- **Suspend the use of the automation immediately as soon as you notice something abnormal in the operation (noises or jolting movements); failure to follow this warning may cause serious danger and accidents.**
- **Do not touch moving parts.**
- **Regular maintenance checks must be carried out by qualified personnel according to the maintenance plan.**
- **Maintenance or repairs must only be carried out by qualified technical personnel.**
- **Send a command with the safety devices disabled:**

If the safety devices do not work properly or are out of order, the gate can still be operated.

When the safety devices have intervened, the automation can be controlled with a person present through the wired controls. It is not possible to send commands via radio.

If the safety devices are out of order, arrange to repair the automation as soon as possible.

**Releasing  and locking  the gearmotor (manual manoeuvre)**

The gearmotor is equipped with a mechanical system that allows for opening and closing the gate manually.

Manual operation must be performed in the case of a power outage or in the event of anomalies affecting the system.

In the event of a gearmotor fault, it is still possible to try release the motor to check whether the fault lies in the release mechanism.

To lock the gearmotor, carry out the following operations in reverse order.

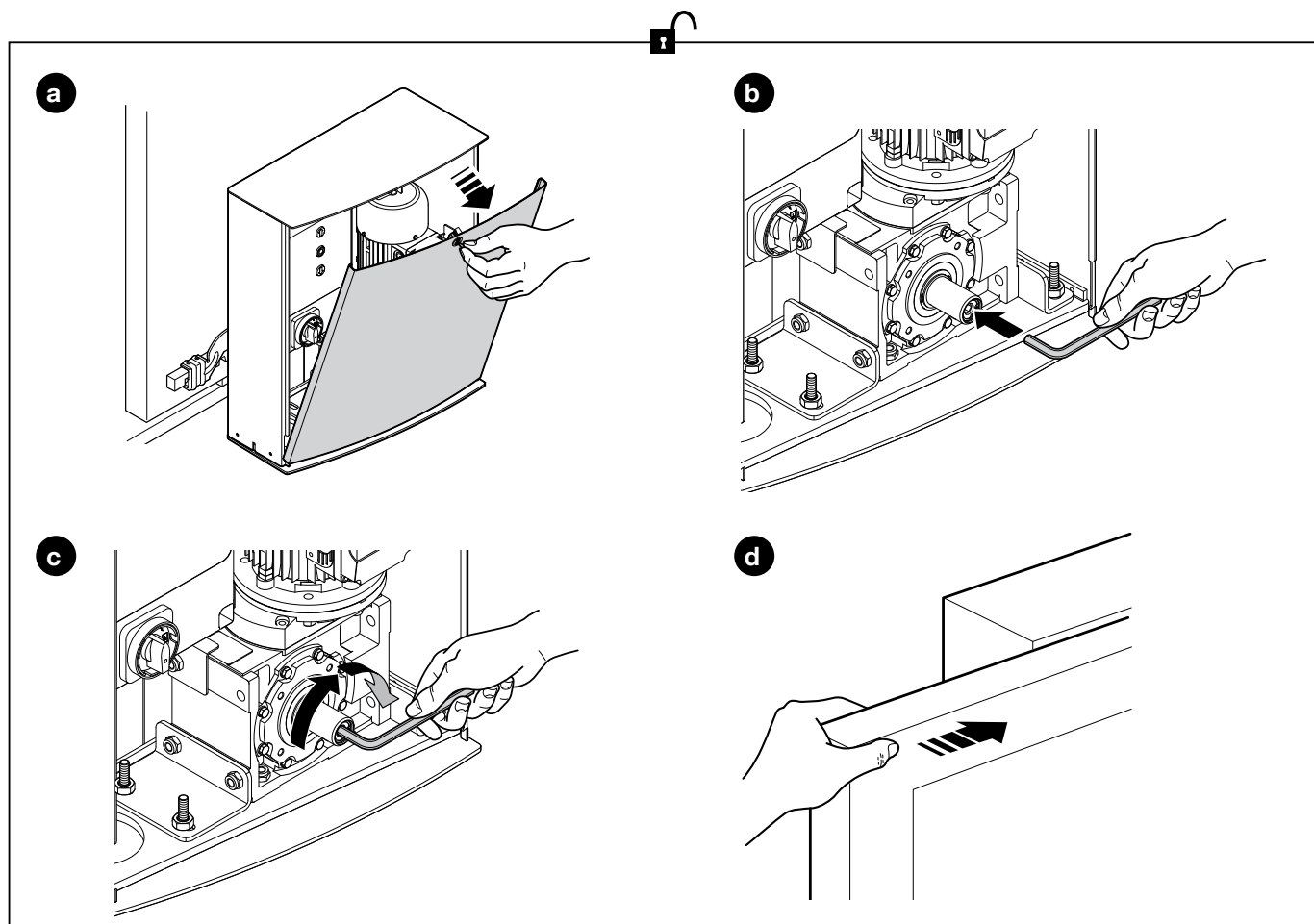

**User-admissible maintenance operations**

The operations that the user must carry out periodically are listed below:

- **Cleaning of the surfaces of the devices: use a slightly damp (not wet) cloth. Do not use substances containing alcohol, benzene, thinners or other flammable substances; the use of these substances may damage the devices and cause fires or electric shocks.**
- **Removal of leaves and stones: disconnect the power supply before proceeding, so as to prevent anyone from moving the gate. If a back-up battery is fitted, disconnect it.**

