

A modern building with large windows and a green wall, with a barrier gate operator system in the foreground. A black car is partially visible on the left. The barrier gate is a red and white striped arm attached to a grey operator box. The operator box has the 'Nice' logo on it. The scene is set on a paved area with a brick pattern in the foreground.

Nice

Barrier gate operator systems



Hermès & Co.

Nice

Nice

Nice

Nice

BF 14



Nice

S/M/L Bar and Wide systems.

The two range of road barrier systems to control accesses in public and private parking areas, even where traffic is heavy.

A complete barrier raising system with practical composition of the bars and an aluminium expansion joint guarantees their robustness, easy transport and optimised management in the warehouse.

S/M/L Bar

Barrier raising systems for every size.

Barrier raising systems for controlling road access in parking areas and private and apartment block access roads, including with heavy traffic.

Integrated solutions for all needs.

Performance, reliability and a long working life.

Essential elegant design.

Meticulous research into materials.

Greater comfort and safety at all times.



Painted aluminium
bar support and cover,
with optional flashing light

With case in
steel with protective electrophoretic
treatment and painted, or case in stain-
less steel

News 2024

**M-Bar and L-Bar are available in
four colour versions: grey, white,
stainless steel and orange.**



Quick and easy access to internal components

- simple removal of cover, separate compartments to protect electronics and mechanics.

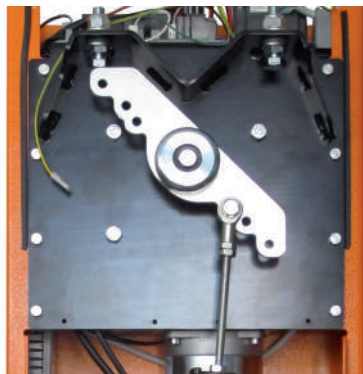

Balancing springs - highly robust, guaranteed for up to 2,000,000 manoeuvres for M-Bar and L-Bar models.

Gearmotor - 24 VDC, powerful and fast.

Control unit located in the upper part of the barrier body - easier programming and maintenance.



Photocells completely invisible from the outside - fixed simply in place in the recesses provided in the barrier body.

Flashing light or optional traffic light for integrated installation in cover



Key release for installation on either side

Elliptical section bar with high resistance to gusts of wind. LED signal lights for integrated installation in the profile



5 models and 3 versions available, up to 7 modular bars from 3 to 9 m long.

The practical composition of the bars with aluminium expansion joint guarantees their robustness and makes them easier to transport and handle at the warehouse.

To obtain a complete barrier raising system:

1. Choose the gearmotor
2. Associate the bar
3. Complete the system with optional accessories.

Composition bars and accessories

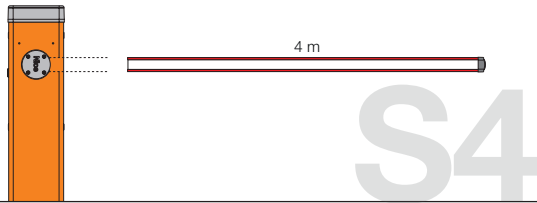

S4BAR

With dedicated 4 m bar

Provision for:
protective rubber trim, signal lights.

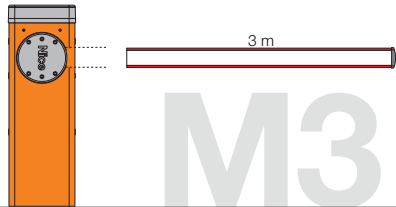

M3BAR

With 3 m long bar

Provision for:
protective rubber trim, signal lights.

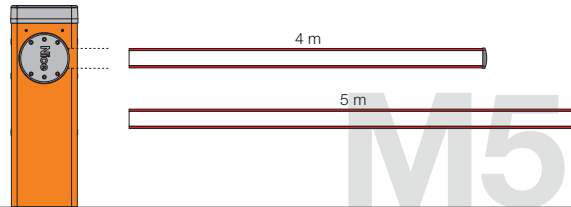

M5BAR

With 4 m long bar

Provision for:
protective rubber trim, signal lights,
rack (1 pc.), movable support.

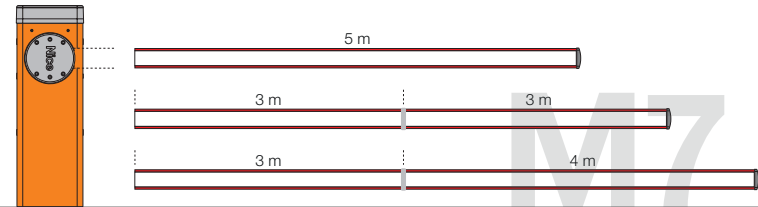

M7BAR

With 5 m long bar

Provision for:
protective rubber trim,
signal lights, rack (2 pc.),
movable support.

With 6 m bar (3+3 m)*

Provision for:
protective rubber trim, signal lights,
rack (2 pc.), movable support.

With 7 m bar (3+4 m)*

Provision for:
protective rubber trim, signal lights,
movable support.

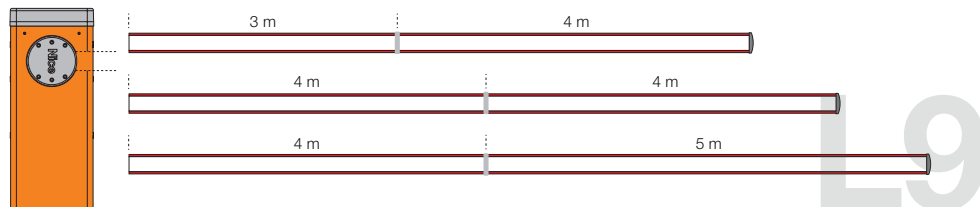

L9BAR

With 7 m bar (3+4 m)*

Provision for:
protective rubber trim, signal lights, rack
(3 pc.), movable support.

With 8 m bar (4+4 m)*

Provision for:
protective rubber trim, signal lights, rack
(3 pc.), movable support.

With 9 m bar (4+5 m)*

Provision for:
protective rubber trim, signal lights.

* Use joint XBA9 to assemble the bars. **N.B.** Bars and accessories are not included in the gearmotor code.

Nice

S-Bar

Electromechanical road barrier system for road access control.

For 4 m bars.



Gearmotor, 24 VDC, with integrated control unit.

Strength and reliability: sturdy steel structure, new robust balancing springs guaranteed to 500,000 cycles and elliptical section bar with high resistance to gusts of wind.

Optional flashing light for integrated installation in cover.

Easier programming and maintenance: separate compartments for the electronics and mechanics protect internal parts from possible hazards.

Quick and easy access to the control unit located in the top part of the barrier body.

The photocells, completely invisible from the outside, are fixed simply in place in the recesses provided in the barrier body.

More reliability and safety: obstacle detection and monitoring of motor draw throughout automation movement.

Automatic fault diagnosis during operation and subsequent indication of type through different combinations of flashes.

Provision for connection of latest generation optical and resistive sensitive edges (8.2 KOhm resistance).

Energy saving: when the system is not in use, it switches to stand-by mode, reducing power consumption.

No blackouts: operation in event of power failures with the optional batteries housed under the control unit.

Side release with Nice triangular key: can be installed on either side.

BlueBus

BiDi

24V

Yubii

Solemyo

Opera



Programmable via App

With Pro-View or Bidi-WiFi & MyNice Pro App, installing Nice Gate&Door systems is even easier and more convenient.



TO OBTAIN A COMPLETE BARRIER RAISING SYSTEM:

1. CHOOSE THE GEARMOTOR

2. ASSOCIATE THE BAR

3. COMPLETE THE SYSTEM
WITH OPTIONAL ACCESSORIES

For 4 m long bars, non-reversible 230 VAC, 24 VDC motor, including anchorage base:

Code	Description
S4BAR	With case in steel and with protective electrophoretic treatment and painted
S4BARI	With stainless steel case

COMMON ACCESSORIES

Code	Description	Pcs. Pack
XBA19	White painted aluminium bar 45x58x4270 mm	1
XBA20	Spare control unit for S4BAR	1
XBA13	Bumper rubber, 1 m	9
WA10	Red reflective adhesive strip	24
SIA1	Anchorage base with clamps	1
XBA7	Flashing light for integrated installation in cover	1
XBA4	Plug-in signal lights for mounting on the top or bottom of the bar. Length 4 m	1
WA11	Adjustable support for bars	1
PS124	24 V battery with integrated battery charger	1
SYKCE	Solar power supply kit consisting of SYP photovoltaic panel and PSY24 battery box with charging control circuit	1

Find out more on page → 148.

TECHNICAL SPECIFICATIONS

Code	S4BAR	S4BARI
ELECTRICAL SPECIFICATIONS		
Power supply (VAC 50/60 Hz)		230
Power supply (VDC)		24
Power (W)		300
PERFORMANCE DATA		
Speed (S)		≥4 - >5 (with XBA4 accessory)
Torque (Nm)		100
Working cycle (cycles/hour)*		100
DIMENSIONAL AND GENERAL DATA		
Protection class (IP)		44
Operating temperature (°C Min/Max)		-20 ÷ +55
Dimensions (mm)		330x179,5x1146 h
Weight (kg)		35

* At nominal torque.

DIMENSIONS

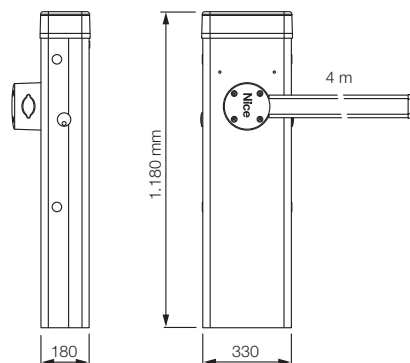

COMPATIBILITY WITH CONTROL SYSTEMS AND ACCESSORIES

S4BAR S4BARI
Control unit/Receiver
Integrated*
<ul style="list-style-type: none"> • OXIBD / OXILR
Transmitter
<ul style="list-style-type: none"> • ERA INTI - 2 channels, 433.92 MHz, different colours • ERA ONE / MYGO - 1, 2, 4 or 9 channels, 433.92 MHz • ERA ONE BD / MYGOBD / ERA ONE LR • ERA FLOR / DOMi
Photocells
EPS - Slim / EPM - Medium / EPL - Large
<ul style="list-style-type: none"> • EPSB - Slim, BlueBUS / EPMB - Medium, BlueBUS / EPLB - Large, BlueBUS • EPMOR - Medium, reflective • EPMORB - Medium, BlueBUS, reflective • EPMOW - Medium, wireless self-synchronised
F210 - Synchronised, adjustable / FT210 - For sensitive edges
<ul style="list-style-type: none"> • F210B - BlueBUS • FT210B - For sensitive edges, BlueBUS
Flashing light
ELAC
<ul style="list-style-type: none"> • ELDC • WLT - Multifunction LED light

* Radio receiver not compatible with the O-box functions of the Opera system.

Nice

M-Bar

Electromechanical road barrier system for road access control.

For bars from 3 to 7 m long.

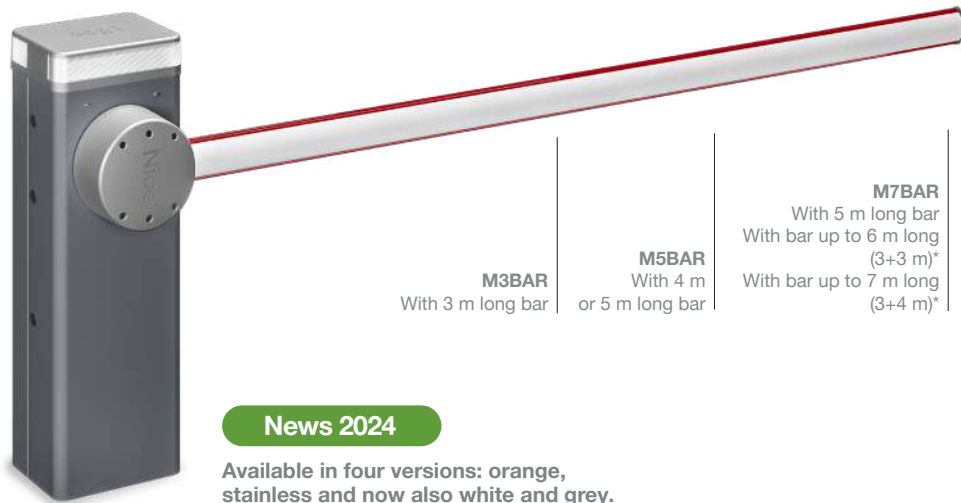

M3BAR
With 3 m long bar

M5BAR
With 4 m
or 5 m long bar

M7BAR
With 5 m long bar
With bar up to 6 m long
(3+3 m)*
With bar up to 7 m long
(3+4 m)*

News 2024

Available in four versions: orange, stainless and now also white and grey.



* Use joint XBA9 to assemble the bars.

BlueBus

24V

BiDi

Yubii

Solemyo

Opera

Programmable via App

With Pro-View or Bidi-WiFi & MyNice Pro App.

Gearmotor, 24 VDC, with integrated control unit.

Simplified programming: control unit with display and joystick to make setting operating parameters even faster.

The control unit has an output to power 24 VDC devices and two inputs to control loop detectors via the LP21 and LP22 accessories.

Modular: practical composition of the bars with the aluminium expansion joint.

Smart control of the movement of two opposing automations thanks to the “master/slave” function.

Strength and reliability: sturdy steel structure, new robust balancing springs guaranteed for up to 2,000,000 cycles and elliptical section bar with high resistance to gusts of wind.

Optional flashing or traffic light for integrated installation in cover.

Movement control with encoder and electromechanical limit switches.

Easier programming and maintenance: separate compartments for the electronics and mechanics protect internal parts from possible hazards.

Quick and easy access to the control unit located in the top part of the barrier body.

The photocells, completely invisible from the outside, are fixed simply in place in the recesses provided in the barrier body.

More reliability and safety: obstacle detection and monitoring of motor draw throughout automation movement.

Automatic fault diagnosis during operation and subsequent indication of type through different combinations of flashes.

Provision for connection of latest generation optical and resistive sensitive edges (8.2 KOhm resistance).

Energy saving: when the system is not in use, it switches to stand-by mode, reducing power consumption.

No blackouts: operation in event of power failure with the optional batteries (PS224) housed in the motor.

Side release with metal key: can be installed on either side.

For 3 m long bars, non-reversible 230 VAC, 24 VDC motor, including anchorage base:

Code	Description
M3BAR	Steel case, protective cataphoresis treatment, painted orange. For intensive use
M3BARI	With stainless steel case
M3BARWH	Steel case, protective cataphoresis treatment, painted white. For intensive use
M3BARGR1	Steel case, protective cataphoresis treatment, painted grey. For intensive use

For 4 or 5 m long bars, non-reversible 230 VAC, 24 VDC motor, including anchorage base:

Code	Description
M5BAR	Steel case, protective cataphoresis treatment, painted orange. For intensive use
M5BARI	With stainless steel case
M5BARWH	Steel case, protective cataphoresis treatment, painted white. For intensive use
M5BARGR1	Steel case, protective cataphoresis treatment, painted grey. For intensive use

For 5, 6 or 7 m long bars, non-reversible 230 VAC, 24 VDC motor, including anchorage base:

Code	Description
M7BAR	Steel case, protective cataphoresis treatment, painted orange. For intensive use
M7BARI	With stainless steel case
M7BARWH	Steel case, protective cataphoresis treatment, painted white. For intensive use
M7BARGR1	Steel case, protective cataphoresis treatment, painted grey. For intensive use

TO OBTAIN A COMPLETE BARRIER RAISING SYSTEM:

1. CHOOSE THE GEARMOTOR

2. ASSOCIATE THE BAR

3. COMPLETE THE SYSTEM
WITH OPTIONAL ACCESSORIES

COMMON ACCESSORIES

Code	Description	Pcs. Pack
BCU1	Control units	1
LP21	Magnetic loop detector 1 channel	1
LP22	Magnetic loop detector 2 channels	1
XBA13	Bumper rubber, 1 m	9
WA10	Red reflective adhesive strip	24
XBA8	Traffic light for integrated installation in cover	1
XBA7	Flashing light for integrated installation in cover	1
XBA16	Anchorage base with clamps	1
WA11	Adjustable support for bars	1
PS224	Buffer battery 24 VDC	1
SYKCE	Solar power supply kit consisting of SYP photovoltaic panel and PSY24 battery box with charging control circuit	1

ACCESSORIES FOR M3BAR

Code	Description	Pcs. Pack
XBA15	White painted aluminium bar 69x92x3150 mm	1
XBA4	Plug-in signal lights for mounting on the top or bottom of the bar. Length 4 m	1
XBA10	Swivel attachment for bars up to 4 m long	1
XBA11	Joint for bars (1950 mm to 2400 mm)	1

ACCESSORIES FOR M5BAR

Code	Description	Pcs. Pack
XBA14	White painted aluminium bar 69x92x4150 mm	1
XBA5	White painted aluminium bar 69x92x5150 mm	1
XBA4	Plug-in signal lights for mounting on the top or bottom of the bar. Length 4 m	1
XBA6	Plug-in signal lights for mounting on the top or bottom of the bar. Length 6 m	1
XBA10	Swivel attachment for bars up to 4 m long	1
XBA11	Joint for bars (1950 mm to 2400 mm)	1
WA12	Movable support for bars, reinforced and resistant	1
WA13	Aluminium rack, 2 m	1

ACCESSORIES FOR M7BAR

Code	Description	Pcs. Pack
XBA15	White painted aluminium bar 69x92x3150 mm	1
XBA14	White painted aluminium bar 69x92x4150 mm	1
XBA5	White painted aluminium bar 69x92x5150 mm	1
XBA9	Expansion joint	1
XBA6	Plug-in signal lights for mounting on the top or bottom of the bar. Length 6 m	1
XBA18	Plug-in signal lights for mounting on the top or bottom of the bar. Length 8 m	1
WA12	Movable support for bars, reinforced and resistant	1
WA13	Aluminium rack, 2 m	1

TECHNICAL SPECIFICATIONS

Code	M3BAR	M3BARI	M5BAR	M5BARI	M7BAR	M7BARI
ELECTRICAL SPECIFICATIONS						
Power supply (VAC 50/60 Hz)				230		
Power supply (VDC)				24		
Power (W)	150		110		110	
PERFORMANCE DATA						
Min-max speed (S)	1,5 ÷ 4		3 ÷ 6		6 ÷ 10	
Torque (Nm)	100		200		300	
Working cycle (cycles/hour)*	500		350		200	
DIMENSIONAL AND GENERAL DATA						
Protection class (IP)	54					
Operating temperature (°C Min/Max)	-20 ÷ +55					
Dimensions (mm)	400x299x1215 h					
Weight (kg)	80				85	

* At nominal torque.

DIMENSIONS

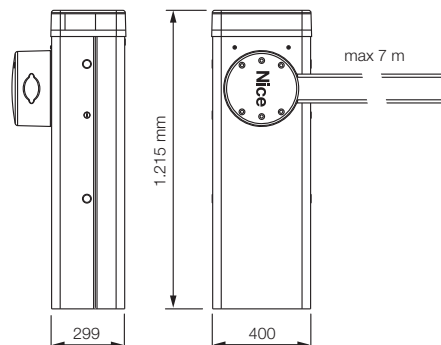

COLOUR VERSIONS



COMPATIBILITY WITH CONTROL SYSTEMS AND ACCESSORIES

M3BAR / M3BARI	M5BAR / M5BARI	M7BAR / M7BARI	
			Control unit/Receiver
			Integrated*
•	•	•	OXIBD / OXILR
			Transmitter
•	•	•	ERA INTI - 2 channels, 433.92 MHz, different colours
•	•	•	ERA ONE / MYGO - 1, 2, 4 or 9 channels, 433.92 MHz
•	•	•	ERA ONE BD / MYGOBD / ERA ONE LR
•	•	•	ERA FLOR / DOMi
			Photocells
			EPS - Slim / EPM - Medium / EPL - Large
•	•	•	EPSB - Slim, BlueBUS / EPMB - Medium, BlueBUS / EPLB - Large, BlueBUS
•	•	•	EPMOR - Medium, reflective
			EPMORB - Medium, BlueBUS, reflective
•	•	•	EPMOW - Medium, wireless self-synchronised
•	•	•	F210 - Synchronised, adjustable / FT210 - For sensitive edges
•	•	•	F210B - BlueBUS
•	•	•	FT210B - For sensitive edges, BlueBUS
			Flashing light
			ELAC
•	•	•	ELDC
•	•	•	WLT - Multifunction LED light

* Radio receiver not compatible with the O-box functions of the Opera system.

L-Bar

Electromechanical road barrier system for road access control.

Powerful and fast, for 7 to 9 m long bars.



News 2024

Available in four versions: orange, stainless and now also white and grey.



Gearmotor, 24 VDC, with integrated control unit.

Simplified programming: control unit with display and joystick to make setting operating parameters even faster.

The control unit has an output to power 24 VDC devices and two inputs to control loop detectors via the LP21 and LP22 accessories.

Modular: practical composition of the bars with the aluminium expansion joint.

Smart control of the movement of two opposing automations thanks to the **“master/slave” function.**

Strength and reliability: sturdy steel structure, new robust balancing springs guaranteed for up to 2,000,000 cycles and elliptical section bar with high resistance to gusts of wind.

Optional flashing or traffic light for integrated installation in cover.

Movement control with encoder and electromechanical limit switches.

Easier programming and maintenance: separate compartments for the electronics and mechanics protect internal parts from possible hazards.

Quick and easy access to the control unit located in the top part of the barrier body.

The photocells, completely invisible from the outside, are fixed simply in place in the recesses provided in the barrier body.

More reliability and safety: obstacle detection and monitoring of motor draw throughout automation movement.

Automatic fault diagnosis during operation and subsequent indication of type through different combinations of flashes.

Provision for connection of latest generation optical and resistive sensitive edges (8.2 KOhm resistance).

Energy saving: when the system is not in use, it switches to stand-by mode, reducing power consumption.

No blackouts: operation in event of power failure with the optional batteries (PS224) housed in the motor.

Side release with metal key: can be installed on either side.

BlueBus

BiDi

24V

Yubii

Solemyo

Opera

Programmable via App

With Pro-View or Bidi-WiFi & MyNice Pro App, installing Nice Gate&Door systems is even easier and more convenient.



TO OBTAIN A COMPLETE BARRIER RAISING SYSTEM:

1. CHOOSE THE GEARMOTOR

2. ASSOCIATE THE BAR

3. COMPLETE THE SYSTEM
WITH OPTIONAL ACCESSORIES

For 9 m long bars, non-reversible 230 VAC, 24 VDC motor, including anchorage base:

Code	Description
L9BAR	Steel case, protective cataphoresis treatment, painted orange
L9BARI	With stainless steel case
L9BARWH	Steel case, protective cataphoresis treatment, painted white.
L9BARGR1	Steel case, protective cataphoresis treatment, painted grey.

COMMON ACCESSORIES

Code	Description	Pcs. Pack
XBA15	White painted aluminium bar 69x92x3150 mm	1
XBA14	White painted aluminium bar 69x92x4150 mm	1
XBA5	White painted aluminium bar 69x92x5150 mm	1
XBA9	Expansion joint	1
XBA8	Traffic light for integrated installation in cover	1
XBA7	Flashing light for integrated installation in cover	1
XBA18	Plug-in signal lights for mounting on the top or bottom of the bar. Length 8 m	1
BCU1	Control units	1
LP21	Magnetic loop detector 1 channel	1
LP22	Magnetic loop detector 2 channels	1
XBA13	Bumper rubber, 1 m	9
WA10	Red reflective adhesive strip	24
WA13	Aluminium rack, 2 m	1
XBA17	Anchorage base with clamps	1
WA11	Adjustable support for bars	1
WA12	Movable support for bars, reinforced and resistant	1
WA11	Adjustable support for bars	1
PS224	Buffer battery 24 VDC	1
SYKCE	Solar power supply kit consisting of SYP photovoltaic panel and PSY24 battery box with charging control circuit	1

Find out more on page → 148.

TECHNICAL SPECIFICATIONS

Code	L9BAR	L9BARI
ELECTRICAL SPECIFICATIONS		
Power supply (VAC 50/60 Hz)		230
Power supply (VDC)		24
Power (W)		160
PERFORMANCE DATA		
Min-max speed (S)		11 ÷ 18
Torque (Nm)		400
Working cycle (cycles/hour)*		150
DIMENSIONAL AND GENERAL DATA		
Protection class (IP)		54
Operating temperature (°C Min/Max)		-20 ÷ +55
Dimensions (mm)		500x299x1215 h
Weight (kg)		98

* At nominal torque.

DIMENSIONS

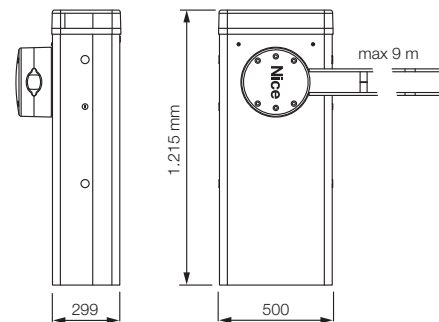

COLOUR VERSIONS

ORANGE
RAL2004STEEL
INOXWHITE
RAL9010GREY
RAL7015

COMPATIBILITY WITH CONTROL SYSTEMS AND ACCESSORIES

L9BAR / L9BARI
Control unit/Receiver
Integrated*
• OXIBD / OXILR
Transmitter
• ERA INTI - 2 channels, 433.92 MHz, different colours
• ERA ONE / MYGO - 1, 2, 4 or 9 channels, 433.92 MHz
• ERA ONE BD / MYGOBD / ERA ONE LR
• ERA FLOR / DOMI
Photocells
EPS - Slim / EPM - Medium / EPL - Large
• EPSB - Slim, BlueBUS / EPMB - Medium, BlueBUS / EPLB - Large, BlueBUS
• EPMOR - Medium, reflective
EPMORB - Medium, BlueBUS, reflective
• EPMOW - Medium, wireless self-synchronised
F210 - Synchronised, adjustable / FT210 - For sensitive edges
• F210B - BlueBUS
• FT210B - For sensitive edges, BlueBUS
Flashing light
ELAC
• ELDC
• WLT - Multifunction LED light

* Radio receiver not compatible with the O-box functions of the Opera system.

Wide

Solid and essential.



Large front cover for quick and easy access - easily removable reinforced gearmotor support.



Easy maintenance - integrated control unit, removable for ease of wiring and maintenance. No blackouts with the buffer battery for integrated installation in the control unit.



Safety from vandals - photocells integrated in the barrier body, minimum visual impact and maximum protection.

News 2024

WIDEM and WIDEL are available in four colour versions: grey, white, stainless steel and orange.



GREY
RAL7015



WHITE
RAL9010



STEEL
INOX



ORANGE
RAL2004

Removable cover
for easy access
to internal parts

The bar can be mounted on either
the right or left side



Release protected
from external agents
and easy to operate with
triangular key

Case in steel
with protective
electrophoretic treatment
and painted, or case in
stainless steel

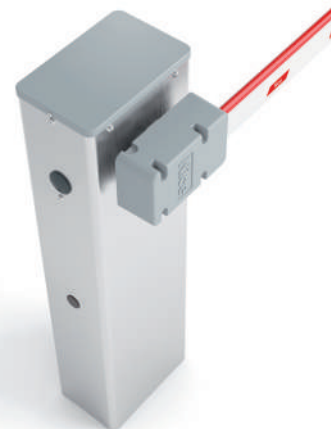

**3 versions available,
up to 5 modular bars
from 3 to 7 m long.**

The composition of the bars with aluminium expansion joint facilitates their transport and handling in storage.

To obtain a complete barrier raising system:

1. Choose the gearmotor
2. Associate the bar
3. Complete the system with optional accessories.

Composition bars and accessories

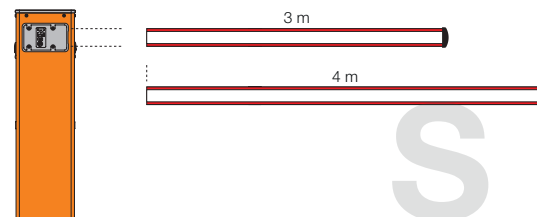

WIDES

With 3 m long bar

Provision for:
protective rubber trim, signal lights,
swivel attachment, rack (1 pc.).

With 4 m long bar

Provision for:
protective rubber trim, signal lights,
swivel attachment.

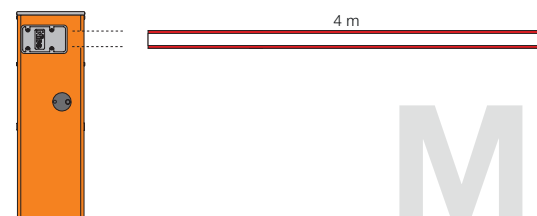

WIDEM

With 4 m bar

Provision for:
protective rubber trim, signal lights, swivel
attachment, jointed attachment, rack (2 pcs.),
movable support.

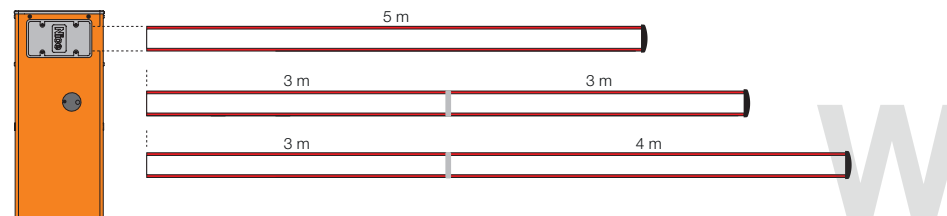

WIDEL

With 5 m long bar

Provision for:
protective rubber trim, signal lights, rack
(2 pc.), movable support.

With 6 m bar (3+3 m)*

Provision for:
protective rubber trim, signal lights, rack
(2 pc.), movable support.

With 7 m bar (3+4 m)*

Provision for:
protective rubber trim, signal lights

* Use joint XBA9 to assemble the bars. **N.B.** Bars and accessories are not included in the gearmotor code.

Wide System

Electromechanical road barrier system for road access control.



News 2024

WIDEM and WIDEL are available in four colour versions: grey, white, stainless steel and orange.



* Use joint XBA9 to assemble the bars.

24V

BiDi

Yubii

Opera

Programmable via App

With Pro-View or Bidi-WiFi & MyNice Pro App.

WIDES
With 3 m
or 4 m long bar

WIDEM
With 4 m
long bar

WIDEL
With 5 m long bar
With bar up to 6 m long
(3+3 m)*
With bar up to 7 m long
(3+4 m)*

Gearmotor, 24 VDC, with integrated control unit, adjustable speed and crush protection function.

Two versions of case, in galvanised and painted steel, or in stainless steel (AISI 304) **in three sizes for bars from 3 to 7 m long.**

Easier programming and maintenance: one integrated control unit for all versions, located in the bottom part of the barrier body.

Large door at the front for quick and easy access.

Easily removable reinforced gearmotor support.

Maximum safety: crush protection in opening and closing; supports inside the barrier body for minimum visual impact.

Speed adjustable electronically from 3.5" (Wide M) to 5" (Wide L) for minimum opening time.

Strength, reliability and ease of installation: elliptical section bar for lighter weight and resistance to gusts of wind; special profile for quick mounting of accessories.

Optional swivel attachment to safeguard the barrier in the event of impact.

The bar can be mounted on either the right or left side.

Easy balancing thanks to a practical spring tension regulator.

No blackouts: operation is guaranteed even without mains power, thanks to the PS234 buffer battery for integrated installation in the control unit.

Release with triangular key protected from external agents.

TO OBTAIN A COMPLETE BARRIER RAISING SYSTEM:



For bars up to 4 m long, non-reversible 230 VAC, 24 VDC motor, including anchorage base:

Code	Description
WIDES	Galvanised and orange-painted steel case
WIDESI	With stainless steel case
WIDEM	Galvanised and orange-painted steel case
WIDEMI	With stainless steel case
WIDEMWH	Galvanised and white-painted steel case
WIDEMGR1	Galvanised and grey-painted steel case

For bars up to 7 m long, non-reversible 230 VAC, 24 VDC motor, including anchorage base:

Code	Description
WIDEL	Galvanised and orange-painted steel case
WIDELI	With stainless steel case
WIDELWH	Galvanised and white-painted steel case
WIDELGR1	Galvanised and grey-painted steel case

COMMON ACCESSORIES

Code	Description	Pcs. Pack
WIA20	Control units	1
XBA13	Bumper rubber, 1 m	9
WA10	Red reflective adhesive strip	24
WA11	Adjustable support for bars	1
WA13	Aluminium rack, 2 m	1
PS324	24 V battery with integrated battery charger	1

ACCESSORIES FOR WIDE S

Code	Description	Pcs. Pack
XBA19	White painted aluminium bar 45x58x4270 mm	1
XBA4	Plug-in signal light for mounting on the top or bottom of the bar. Length 4 m	1
WIA10	Swivel attachment	1
SIA1	Anchorage base with clamps	1

ACCESSORIES FOR WIDE M

Code	Description	Pcs. Pack
XBA19	White painted aluminium bar 45x58x4270 mm	1
XBA4	Plug-in signal light for mounting on the top or bottom of the bar. Length 4 m	1
WIA10	Swivel attachment	1
SIA1	Anchorage base with clamps	1
WA12	Movable support for bars, reinforced and resistant	1
WA11	Bar joint Wide M	1

ACCESSORIES FOR WIDE L

Code	Description	Pcs. Pack
XBA15	White painted aluminium bar 69x92x3150 mm	1
XBA14	White painted aluminium bar 69x92x4150 mm	1
XBA5	White painted aluminium bar 69x92x5150 mm	1
XBA9	Expansion joint	1
XBA6	Plug-in signal light for mounting on the top or bottom of the bar. Length 6 m	1
XBA18	Plug-in signal light for mounting on the top or bottom of the bar. Length 8 m	1
SIA1	Anchorage base with clamps	1
WA12	Movable support for bars, reinforced and resistant	1

Find out more on page → 148.

TECHNICAL SPECIFICATIONS

Code	WIDES	WIDESI	WIDEM	WIDEMI	WIDEL	WIDELI
ELECTRICAL SPECIFICATIONS						
Power supply (VAC 50/60 Hz)				230		
Power supply (VDC)				24		
Draw (A)	1		1,1		0,6	
Power (W)				300		360
PERFORMANCE DATA						
Speed (S)	4		3,5		5	
Torque (Nm)	100		140		200	
Working cycle (cycles/hour)	100		300		200	
DIMENSIONAL AND GENERAL DATA						
Protection class (IP)				54		
Operating temperature (°C Min/Max)				-20 ÷ +55		
Dimensions (mm)	280x178x1000 h		320x205x1000 h		420x205x1030 h	
Weight (kg)	40		46		54	

DIMENSIONS

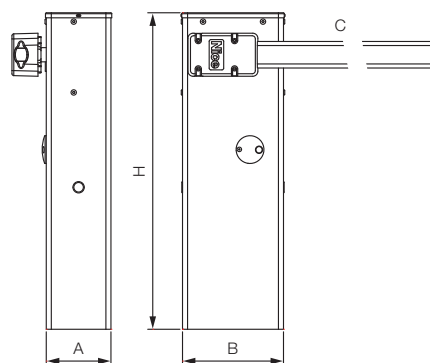

	WIDE S	WIDE M	WIDE L
A	178	208	205
B	280	320	420
C	max. 4 m	max. 4 m	max. 7 m
H	1000	1000	1030

COLOUR VERSIONS



COMPATIBILITY WITH CONTROL SYSTEMS AND ACCESSORIES

WIDES / WIDESI / WIDEM / WIDEMI / WIDEL / WIDELI	Control unit/Receiver
	Integrated*
• • •	OXIBD / OXILR
	Transmitter
• • •	ERA INTI - 2 channels, 433.92 MHz, different colours
• • •	ERA ONE / MYGO - 1, 2, 4 or 9 channels, 433.92 MHz
• • •	ERA ONE BD / MYGOBD / ERA ONE LR
• • •	ERA FLOR / DOMi
	Photocells
• • •	EPS - Slim / EPM - Medium / EPL - Large
	EPSB - Slim, BlueBUS / EPMB - Medium, BlueBUS / EPLB - Large, BlueBUS
• • •	EPMOR - Medium, reflective
	EPMORB - Medium, BlueBUS, reflective
	EPMOW - Medium, wireless self-synchronised
• • •	F210 - Synchronised, adjustable / FT210 - For sensitive edges
	F210B - BlueBUS
	FT210B - For sensitive edges, BlueBUS
	Flashing light
	ELAC
• • •	ELDC
	WLT - Multifunction LED light

* Radio receiver not compatible with the O-box functions of the Opera system.

Nice

A single ecosystem to connect, simplify and control all home automations.

The Barrier raising systems are designed to connect and integrate with the Yubii® ecosystem.

Thanks to the plug-in communication interfaces, the new range of sliding gates motors integrates with your smart home system.



Nice connectivity tools

Smart Home Hub



YUBIIHOME

Gateway for remote control of Nice automations with radio receiver and all smart, Z-Wave™ and WiFi devices.

DESIGNED FOR THE END CONSUMER



Yubii Home App

You can use your smartphone and the Yubii Home app to manage all your Smart Home automations and Z-Wave devices wherever you are.

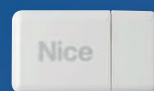

CORE

Wi-Fi gateway for remote control of Nice automations with radio receiver

DESIGNED FOR THE END CONSUMER



MyNice App

You can use your smartphone and the MyNice Welcome app to manage your home's Nice automations wherever you are.



Communication and programming interfaces



IBT4N

Interface for connecting the Pro-View programming unit and IT4WIFI smart interface.



BIDI-WIFI

Plug-in programming interface to configure the automation via smartphone.

With the MyNice app allow the gate and garage door to be controlled locally or remotely with a smartphone or via a voice assistant, without a gateway.



BIDI-ZWAVE

Plug-in communication interface for communicating between Z-Wave™ gateway and Nice motors.



IT4WIFI

Smart Wi-Fi interface to manage gates and garage doors remotely via smartphone.



VOICE COMMANDS

Control your home automation the simplest way possible, including from your smart watch or smart car via Amazon Alexa, Google Assistant or Siri.

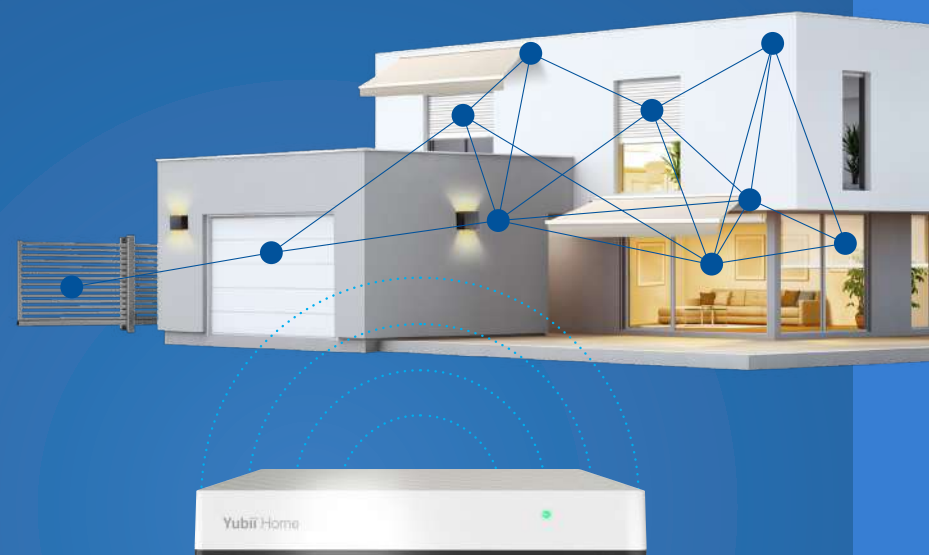

Transmitters

Bidirectional and unidirectional transmitters and receivers

News 2024



MYGO BD

MyGO BD transmitters with 433.92 MHz radio frequency with bidirectional encoding.

Also compatible with Nice O-Code encoded receivers.

The new MYGO remote controls can be programmed via the MyNice Pro app.

Available in three versions: 2, 4 and 8 buttons.



MYGO

MyGO transmitters with 433.92 MHz radio frequency with O-Code encoding.

MyGO FM transmitters, ideal for use in cities or places where multiple devices are installed: 868.46 MHz versions, Rolling Code with FM frequency modulation, guarantee greater immunity to interference.

The new MYGO remote controls can be programmed via the MyNice Pro app.

Available in three versions: 2, 4 and 8 buttons as per customer requirements.

Transmitters and plug-in radio receiver



ERA ONE LR & OXI LR

Long range, bi-directional, 4-key transmitter with LoRa® technology: 3 radio channels and 1 key to interrogate automation status. Integrated NFC technology.

Plug-in bidirectional radio receiver with LoRa® technology.

Range up to 1 km and improved immunity to radio disturbance, also available in kit.

The **ONELRKIT** contains: 2 pcs. ON3ELR, 1 pcs. OXILR, 1 pcs. OX2UBP.

2-channel transmitters



ERA INTI

The colourful line of miniaturised, 2-channel transmitters is available in six colours. 433,92 MHz rolling code, identity code and certificate management, self-learning and integrated proximity receiver; with 72 bit O-Code encoding, also compatible with receivers with Nice FloR encoding.

Control and indicator devices

Digital switches and proximity readers



EDS / EDSI
EDSB / EDSIB



EDSWG



ETP



HSB1



MOCARD

ERA KEYPAD

Digital switches in surface mounted, recessed or 100% wireless versions. Also available with Nice BlueBUS connection technology.

ERA TRANSPONDER READER

Proximity readers for transponder cards and badges, surface-mounted. Also available with Nice BlueBUS connection technology.

Control and indicator devices



ELAC
ELDC

ERA LIGHT

Flashing LED signal light, body particularly shockproof, designed for fixing in various positions. Available in two versions : 90-240 Vac and 12-36 Vdc.

Control devices



EPSA
EPSAB



EPS
EPSB



EPMA / EPMAO
EPMAB / EPMAOB



EPM / EPMB
EPMO / EPMOB



EPL / EPLB / EPLIO / EPLIOB
EPLIO / EPLIOB

ERA PHOTOCELLS SLIM

Fixed synchronised photocells, also with Nice BlueBUS connection technology. Available in anti-intrusion version with metal body. Ideal in confined spaces.

ERA PHOTOCELLS MEDIUM

Fixed or positionable synchronised photocells, also with Nice BlueBUS connection technology. Available in anti-intrusion version with metal body. Ideal for the most widely used systems.

ERA PHOTOCELLS LARGE

Fixed or positionable synchronised photocells, also with Nice BlueBUS connection technology. Available for surface or recessed mounting.



EPMW



EPMOR



ERA PHOTOCELLS MEDIUM

In **wireless** and **reflective** version.



PPK



PPH2



PPH4



PPH1



PPH3

ERA POST

Outdoor aluminium posts for photocells, switches and proximity readers with heights of 500 mm and 1000 mm.

Accessories for rising arm barrier systems

BARS AND ACCESSORIES FOR BARS



XBA19
White painted aluminium bar 45x58x4270 mm for S4BAR, WIDES and WIDEM.

Pcs./pack 1



XBA15
White painted aluminium bar 69x92x3150 mm for M3BAR, M7BAR, LBAR and WIDEL.

Pcs./pack 1



XBA14
White painted aluminium bar 69x92x4150 mm for M5BAR, M7BAR, LBAR, WIDEL.

Pcs./pack 1



XBA5
White painted aluminium bar 69x92x5150 mm for M5BAR, M7BAR, LBAR, WIDEL.

Pcs./pack 1



XBA9
Expansion joint for M3BAR, M7BAR, LBAR, WIDEM and WIDEL.

Pcs./pack 1



XBA13
Bumper rubber, 1 m.
Pcs./pack 9



WA10
Red reflective adhesive strips.
Pcs./pack 24



WA11
Adjustable support for bars.
Pcs./pack 1



WA12
Movable support for bars, reinforced and resistant.
Pcs./pack 1



WA13
2 m aluminium rack for M3BAR, M5BAR, LBAR and WIDE.

Pcs./pack 1



XBA10
Swivel attachment for bars up to 4 m long for M3BAR and M5BAR.

Pcs./pack 1



WIA10
Swivel attachment for WIDES and WIDEM.
Pcs./pack 1



XBA11
Joint for bars (1950 mm to 2400 mm) for M3BAR, M5BAR and WIDEM.
Pcs./pack 1



WIA11
Bar joint for WIDEM.
Pcs./pack 1



XBA4
Plug-in signal lights for mounting on the top or bottom of the bar 4 m long for S4BAR, M3BAR, M5BAR, WIDES and WIDEM.
Pcs./pack 1



XBA6
Plug-in signal lights for mounting on the top or bottom of the bar 6 m long for M5BAR, M7BAR, WIDEL.
Pcs./pack 1



XBA18
Plug-in signal lights for mounting on the top or bottom of the bar 8 m long for M7BAR, LBAR, WIDEL.
Pcs./pack 1



XBA8
Traffic light for integrated installation in cover for MBAR and LBAR.
Pcs./pack 1



XBA7
Flashing light for integrated installation in cover for SBAR, MBAR and LBAR.

Pcs./pack 1



LP21
1-channel magnetic loop detector for MBAR and LBAR.

Pcs./pack 1



LP22
2-channel magnetic loop detector for MBAR and LBAR.

Pcs./pack 1

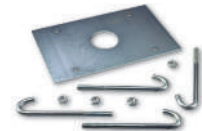

SIA1
Anchorage base with clamps for SBAR, WIDES and WIDEM.

Pcs./pack 1

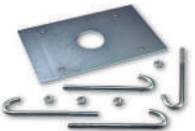

SIA2
Anchorage base with clamps for WIDEL.

Pcs./pack 1



XBA16
Anchorage base with clamps for MBAR.

Pcs./pack 1

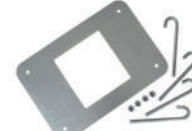

XBA17
Anchorage base with clamps for LBAR.

Pcs./pack 1

SPARE CONTROL UNITS



XBA20
Spare control unit for S4BAR.

Pcs./pack 1



BCU1
Spare control unit for MBAR and LBAR.

Pcs./pack 1

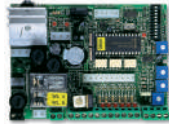

WIA20
Spare control unit for WIDE.

Pcs./pack 1

ACCESSORIES FOR 24V



PS124
24 V battery with integrated battery charger for SBAR.

Pcs./pack 1



PS224
24 VDC buffer battery for MBAR and LBAR.

Pcs./pack 1



PS324
24 V battery with integrated battery charger for WIDE.

Pcs./pack 1

Standard installation diagram for barrier raising systems

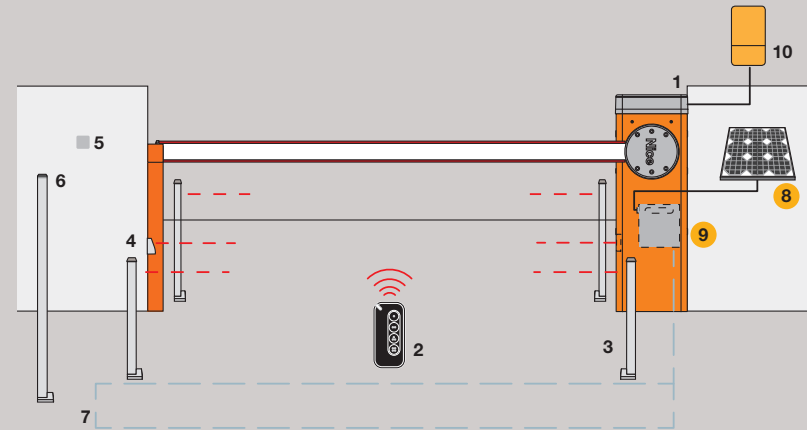

S-BAR / M-BAR / L-BAR

1. Motor 2. Transmitter 3. Post-mounted photocells 4. Photocells 5. Digital or key switch 6. Post-mounted digital or key switch 7. Loop detector 8. SYP solar panel 9. PSY24 battery box 10. Pro-View multifunction interface.

● Solemyo solar power accessories

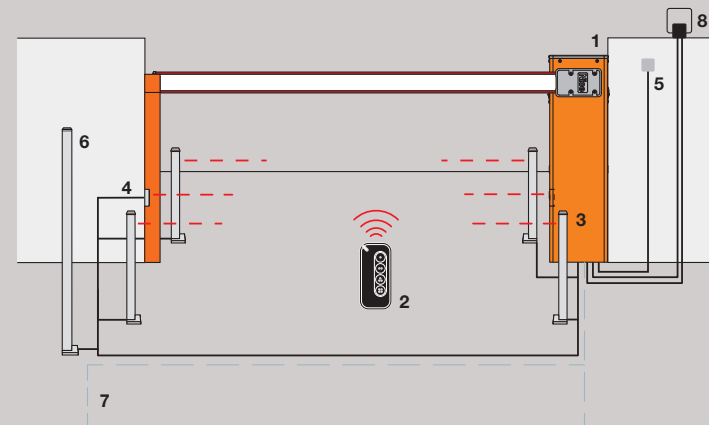

WIDE SYSTEM

1. Motor 2. Transmitter 3. Post-mounted photocells 4. Photocells 5. Digital or key switch 6. Post-mounted digital or key switch 7. Loop detector 8. Flashing light

We make even the smallest of gestures extraordinary.

Nice, a world without barriers.

Automation and control systems for gates, garage doors, blinds, awnings and rolling shutters and alarm systems for all types of space, from private homes to large public buildings.

www.niceforyou.com

Nice SpA
Oderzo, TV, Italy

