

ROX

CE

ROX600

ROX1000

ROX1000/V1

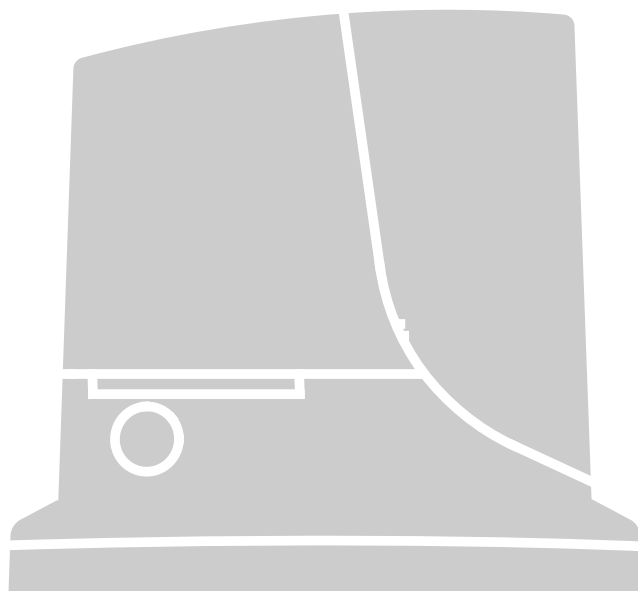

For sliding gates

EN - Instructions and warnings for installation and use

Nice

GENERAL WARNINGS	
SAFETY - INSTALLATION - USE	2
1 - PRODUCT DESCRIPTION AND INTENDED USE	3
2 - OPERATING LIMITS	3
3 - INSTALLATION	4
4 - ELECTRICAL CONNECTIONS	
4.1 - Types of electrical cables	9
4.2 - Electrical cable connections	9
5 - STARTING THE AUTOMATION AND CHECKING THE CONNECTIONS	
5.1 - Hooking the automation up to the mains	10
6 - TESTING AND COMMISSIONING	
6.1 - Testing	11
6.2 - Commissioning	12
7 - PROGRAMMING	
GLOSSARY	12
7.1 - Control unit: programming keys	13
7.1.1 - <i>Trimmer</i>	13
7.2 - Programmable functions	14
7.3 - Integrated radio receiver	15
7.3.1 - <i>Memorisation of radio transmitters</i>	15
7.3.2 - <i>"Remote" memorisation</i>	16
7.3.3 - <i>Deleting radio transmitters</i>	16
8 - DETAILED INFORMATION	
8.1 - Adding or removing devices	17
8.2 - Power for external devices	17
8.3 - Total deletion of the receiver's memory	17
8.4 - Diagnostics	17
8.4.1 - <i>Control unit signals</i>	17
9 - SCRAPPING	18
10 - BASIC TROUBLESHOOTING...	18
11 - MAINTENANCE	19
12 - TECHNICAL SPECIFICATIONS	19
CE DECLARATION OF CONFORMITY	20
User manual (<i>end user version</i>)	21

GENERAL WARNINGS SAFETY - INSTALLATION - USE (instructions translated from Italian)

ATTENTION Important safety instructions. Follow all instructions as improper installation may cause serious damage
ATTENTION Important safety instructions. It is important for you to comply with these instructions for your own and other people's safety. Keep these instructions

- Before commencing the installation, check the "Technical characteristics" (in this manual), in particular whether this product is suitable for automating your guided part. If it is not suitable, DO NOT continue with the installation
- The product cannot be used before it has been commissioned as specified in the chapter on "Testing and commissioning"

ATTENTION According to the most recent European legislation, the implementation of an automation system must comply with the harmonised standards provided by the Machinery Directive in force, which enables declaration of the presumed conformity of the automation. Taking this into account, all operations regarding connection to the electricity grid, as well as product testing, commissioning and maintenance, must be performed exclusively by a qualified and skilled technician!

- Before proceeding with the installation of the product, check that all the materials are in good working order and suited to the intended applications
- This product is not intended to be used by persons (including children) whose physical, sensory or mental capacities are reduced, or who lack the necessary experience or skill
- Children must not play with the appliance
- Do not allow children to play with the fixed control devices of the product. Keep the remote controls away from children.

ATTENTION In order to avoid any danger from inadvertent resetting of the thermal cut-off device, this appliance must not be powered through an external switching device, such as a timer, or connected to a supply that is regularly powered or switched off by the circuit

- Provide a disconnection device (not supplied) in the plant's power supply grid, with a contact opening distance permitting complete disconnection under the conditions dictated by overvoltage category III
- Handle the product with care during installation, taking care to avoid crushing, denting or dropping it, or allowing contact with liquids of any kind. Keep the product away from sources of heat and naked flames. Failure to observe the above can damage the product, and increase the risk of danger or malfunction. Should this happen, stop installation immediately and contact Customer Service
- The manufacturer assumes no liability for damage to property, items or persons resulting from non-compliance with the assembly instructions. In such cases the warranty for material defects is excluded
- The weighted sound pressure level of the emission A is lower than 70 dB(A)
- Cleaning and maintenance to be carried out by the user must not be carried out by unsupervised children
- Before working on the system (maintenance, cleaning), always disconnect the product from the mains power supply
- Check the system periodically, in particular all cables, springs and supports to detect possible imbalances, signs of wear or damage. Do not use if repairs or adjustments are necessary, since installation failure or an incorrectly balanced door may cause injury
- The packing materials of the product must be disposed of in compliance with local regulations
- When operating a biased-off switch, make sure that other persons are kept away
- When operating the gate, keep an eye on the automated mechanism and keep all bystanders at a safe distance until the movement has been completed
- Do not operate the product if anyone is working nearby; disconnect its power supply before permitting such work to be done
- If the power cable is damaged, it must be replaced by the manufacturer or by an appointed servicing company or similarly qualified person in order to prevent any form of risk

INSTALLATION WARNINGS

- Prior to installing the drive motor, check that all mechanical components are in good working order and properly balanced, and that the gate moves correctly
- If the gate or door being automated has a pedestrian gate, then the system must include a control device that will inhibit the operation of the motor when the pedestrian gate is open
- Make sure that the control devices are kept far from moving parts but nonetheless in a visible position. Unless a selector is used, the control devices must be installed at a height of at least 1.5 m and must not be accessible
- That windows, having a gap exceeding 200 mm when open, are to be closed using a biased-off switch if the opening movement is controlled by a fire-sensing system
- Ensure that entrapment between the driven part and the surrounding fixed parts due to the opening movement of the driven part is avoided
- Permanently fix the label concerning the manual release adjacent to its actuating member
- After installing the drive motor, make sure that the mechanism, protective system and all manual manoeuvres operate properly

1 PRODUCT DESCRIPTION AND INTENDED USE

ROX is an electromechanical gearmotor intended for automating residential sliding gates: it is equipped with an electronic control unit with integral radio receiver (433.92 MHz with FLO, FLOR, OPERA, HCS SMILO, etc. coding)

⚠ CAUTION! – All uses other than the intended use described and use in environmental conditions other than those described in this manual should be considered improper and forbidden!

2 APPLICATION LIMITS

Table 1: limits of application in everyday use.

Table 2: limits of application relating to the gate's size and weight.

The effective suitability of ROX to automate a particular sliding gate depends on the friction as well as other correlated factors, such as ice, that could interfere with the movement of the gate.

Measure the force required to move the gate through its entire stroke and check that this does not exceed 25% of the 'maximum force' (chapter 12 - technical specifications): this leaves a suitable margin for unfavourable climatic conditions which can increase friction.

Table 1 – Application limits			
	ROX600	ROX1000	ROX1000/V1
Type of limit switch	electromechanical	electromechanical	electromechanical
Optimal width of gate section (recommended)	5 m	5 m	5 m
Max. gate weight	600 kg	1000 kg	1000 kg
Peak thrust	18 Nm	24 Nm	24 Nm
Corresponding to maximum force	600 N	800 N	800 N

Table 2 – Application limits						
Leave width (m)	ROX600		ROX1000		ROX1000/V1	
	Max. no. of cycles/hour	Max. no. of consecutive cycles	Max. no. of cycles/hour	Max. no. of consecutive cycles	Max. no. of cycles/hour	Max. no. of consecutive cycles
Up to 4	40	20	40	20	60	30
4 ÷ 6	25	13	25	13	30	15
6 ÷ 8	20	10	20	10	24	12
8 ÷ 10	-	-	-	-	16	8
10 ÷ 12	-	-	-	-	-	-

⚠ Caution! Any other use or use with dimensions greater than specified is non-conforming. Nice declines all liability for damage and injury resulting for non-conforming use.

3 INSTALLATION

⚠ Important! Before installing the product, refer to chapters 2 and 12 (technical specifications).

Fig. 1 shows the contents of the package: check that everything is present and correct.

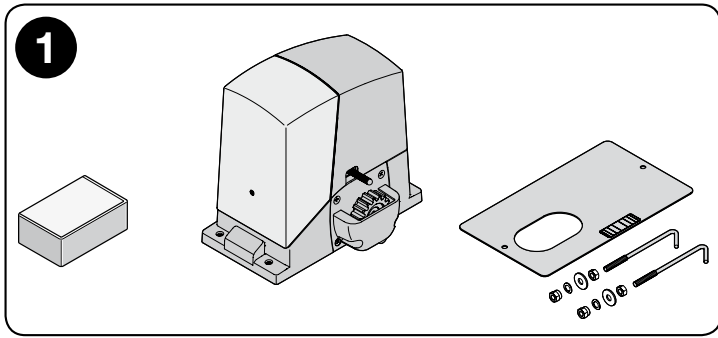
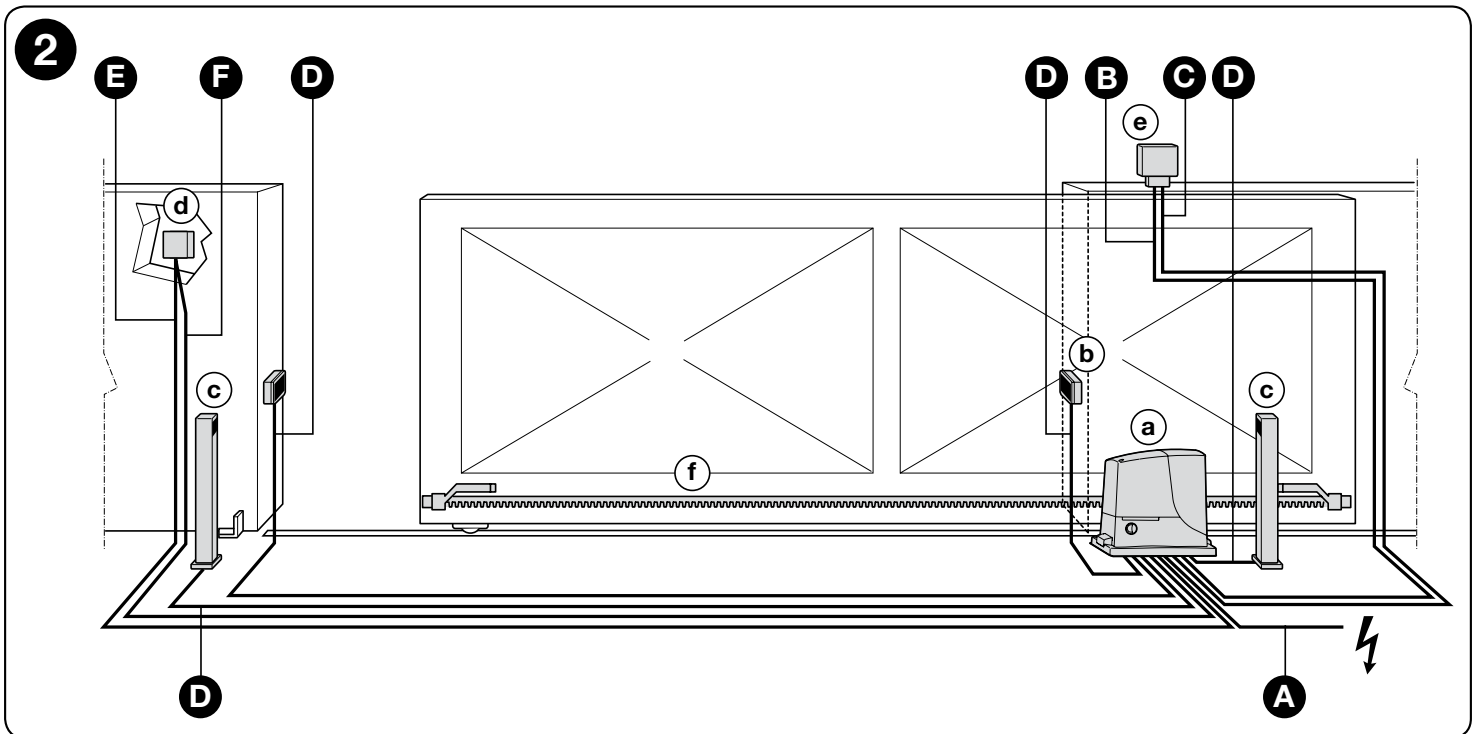
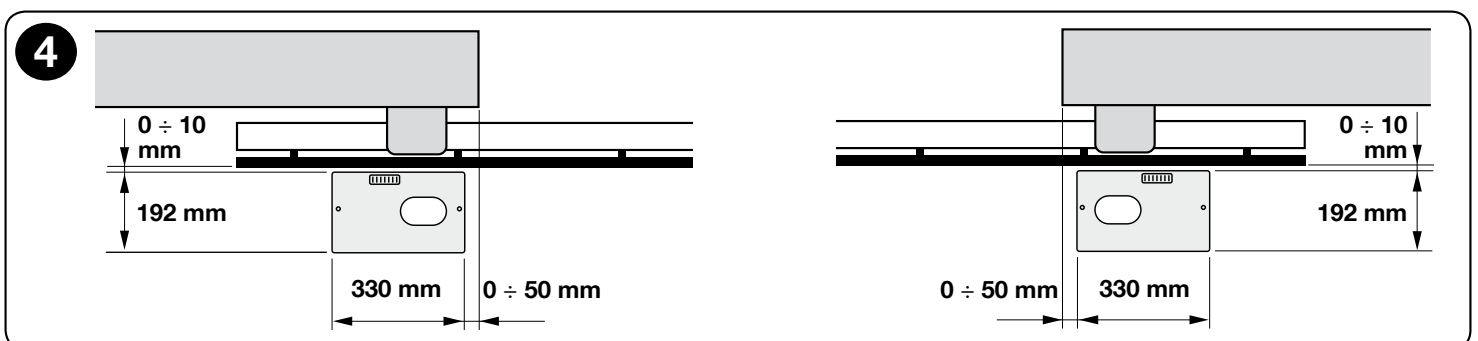
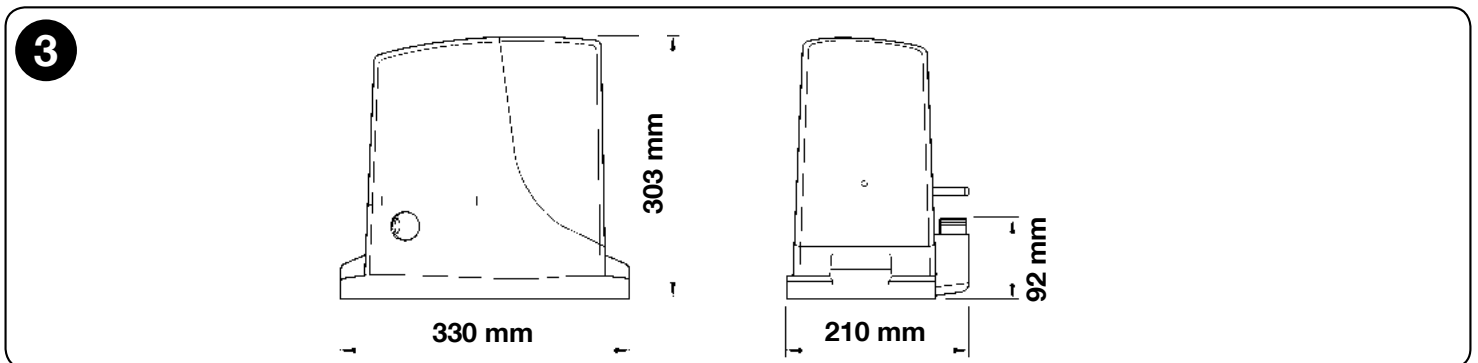

Fig. 2 shows the location of the components of a typical installation using Nice accessories:

- a - ROX gearmotor
- b - photocells
- c - posts for photocells
- d - Key switch / digital keypad
- e - flasher
- f - rack



Before installing the system, check the gearmotor's clearance (fig. 3) and installation dimensions (fig. 4):



01. Dig the foundation and route the electric cable ducting

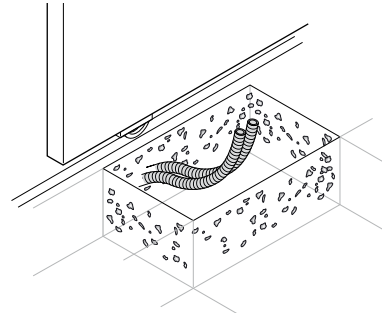

02. Secure the two anchors to the foundation plate with one nut above and one below.

⚠ Tighten the lower nut in such a way that the thread protrudes by 25/35 mm.

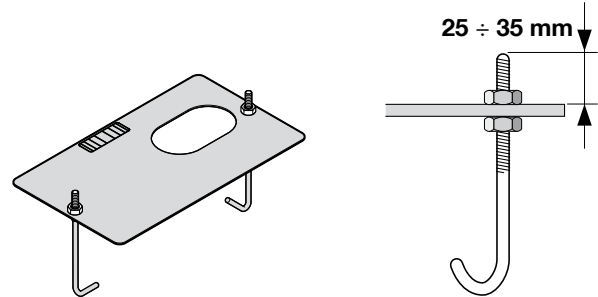

03. Now cast the concrete to secure the foundation plate.

⚠ Before the concrete hardens, make sure the foundation plate is perfectly level and parallel to the gate.

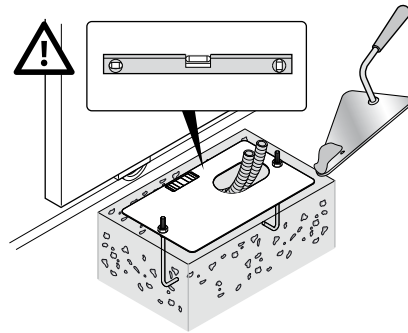

04. Allow the concrete to harden.

05. Secure the gearmotor:

a - Remove the top anchor nuts

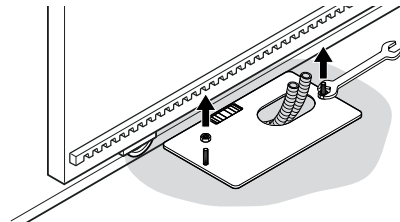

b - rest the gearmotor on the anchor dowels: make sure that it is parallel with the gate section

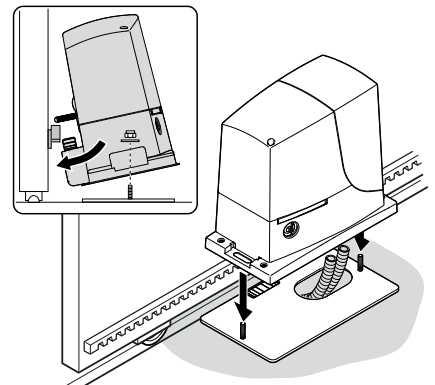

c - fit the provided washers and nuts and hand tighten them

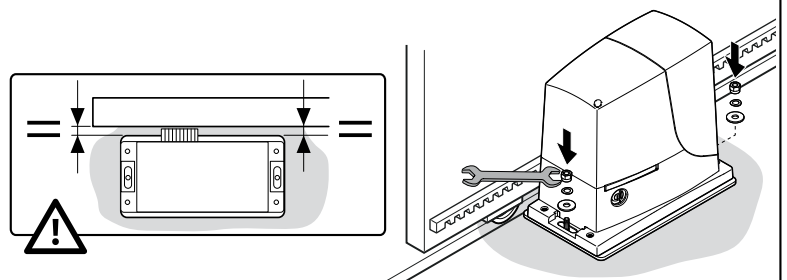

d - screw down the adjuster screws so that the gearmotor is at the proper height, leaving a gap of 1-2 mm between the pinion and the rack (this is to prevent the gate loading the gearmotor shaft)

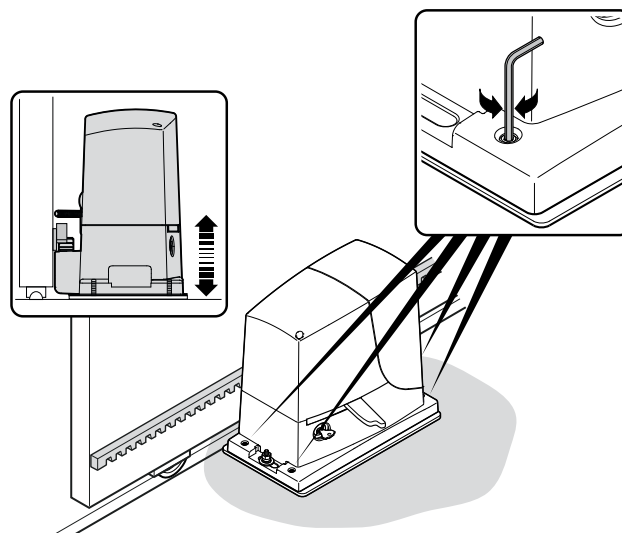

e / f / g - release the gearmotor

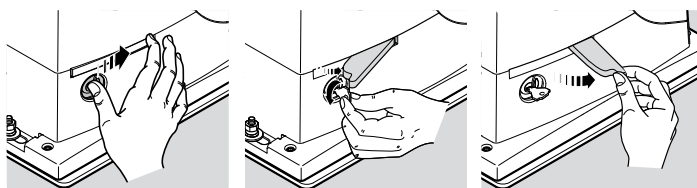

h - open the gate fully by hand

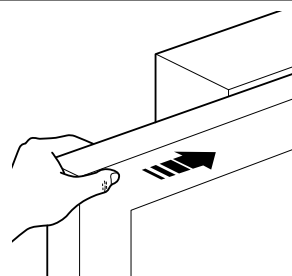

i - rest the first section of rack on the gearmotor's pinion: make sure that it corresponds to the start of the gate section and that there is a gap of 1-2 mm between the rack and the pinion itself (this is to prevent the gate loading the gearmotor shaft)

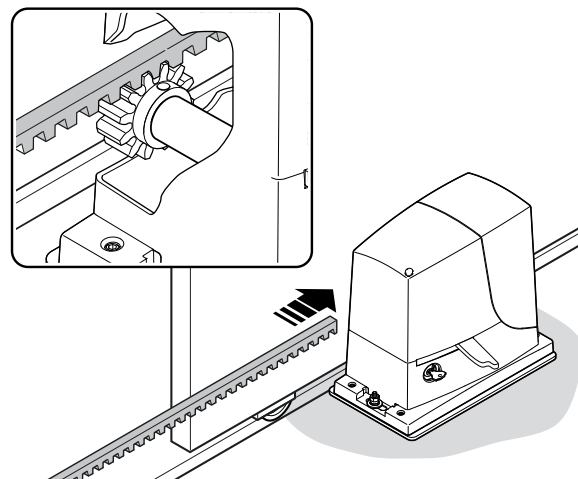

l - secure the rack section

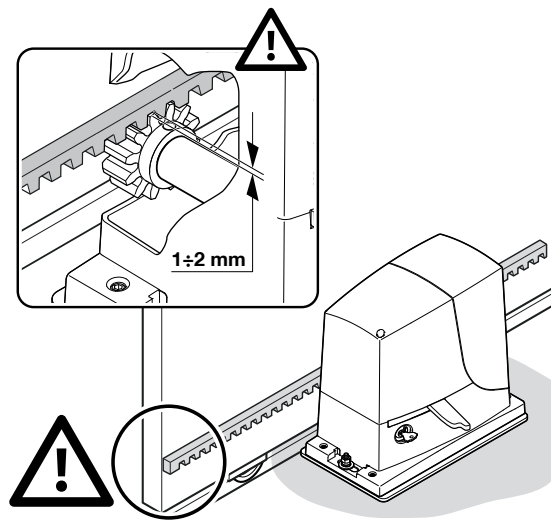

m - slide the gate by hand and, using the pinion as a reference, install the other sections of rack

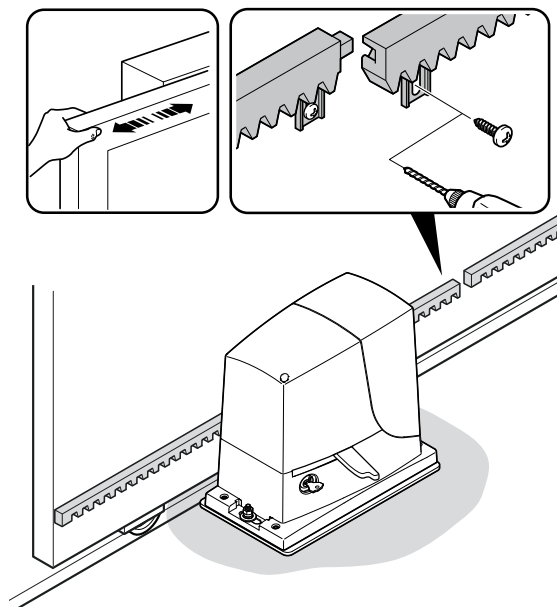

n - cut any excess rack off the end

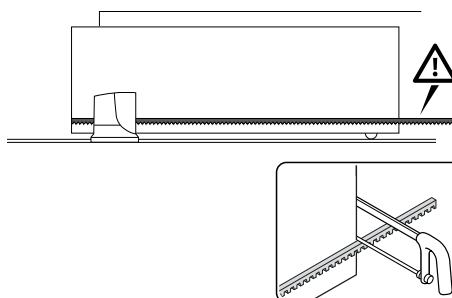

06. Slide the gate open and closed by hand to check that the rack is properly aligned with the pinion.
N.B.: make sure that there is a gap of 1-2 mm between the rack and pinion for the entire length of the gate

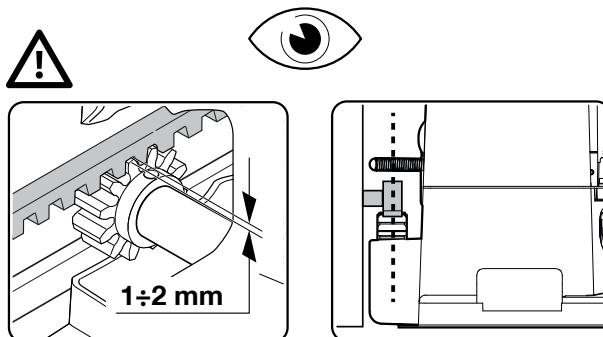
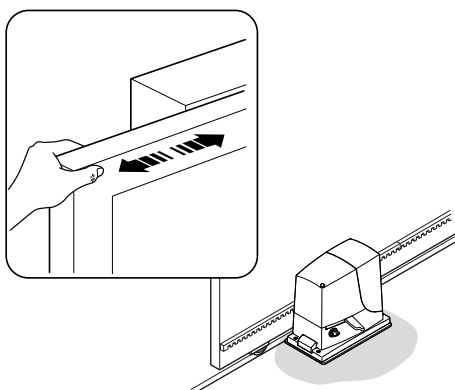

07. Tighten the nuts securing the gearmotor to the foundation plate fully down and cover the nuts with their caps

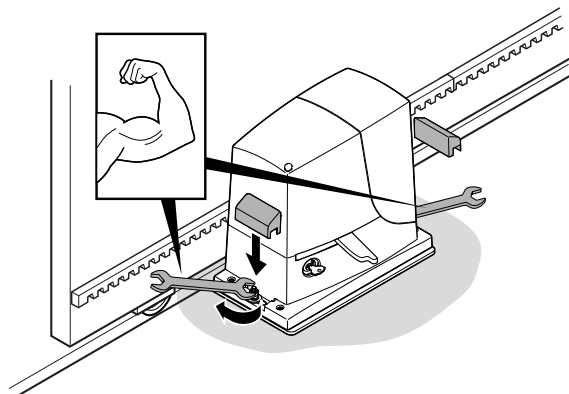

08. Install the OPEN and CLOSE limit switch brackets: proceed in the same way for each limit switch

OPEN:

- a - slide the gate open by hand, stopping it 2/3 cm before the mechanical stop
- b - slide the limit switch bracket along the rack in the open direction until the limit switch trips (you will hear it click)
- c - after you hear the 'click', move the bracket further forwards by 2 cm (minimum)
- d - secure the bracket to the rack with the provided grub screws

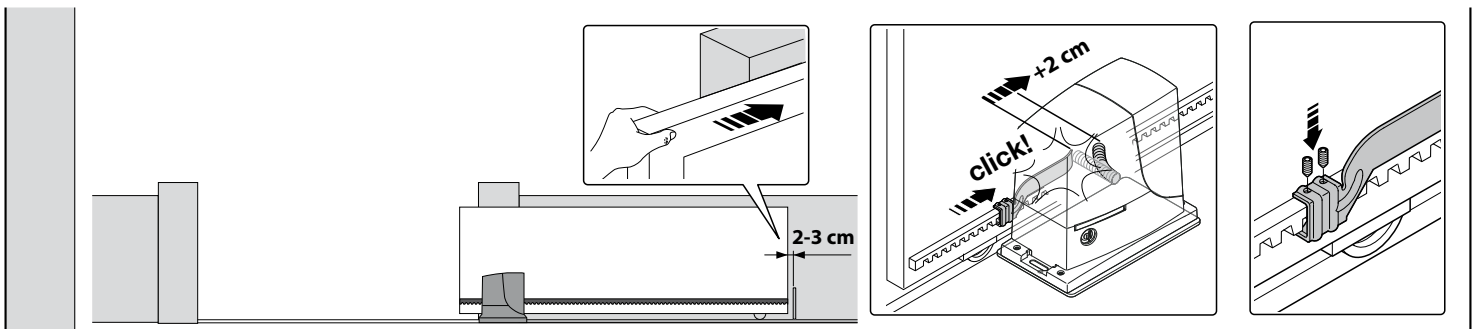

CLOSE:

- a - slide the gate closed by hand, stopping it 2/3 cm before the mechanical stop
- b - slide the limit switch bracket along the rack in the close direction until the limit switch trips (you will hear it click)
- c - after you hear the 'click', move the bracket further forwards by 2 cm (minimum)
- d - secure the bracket to the rack with the provided grub screws

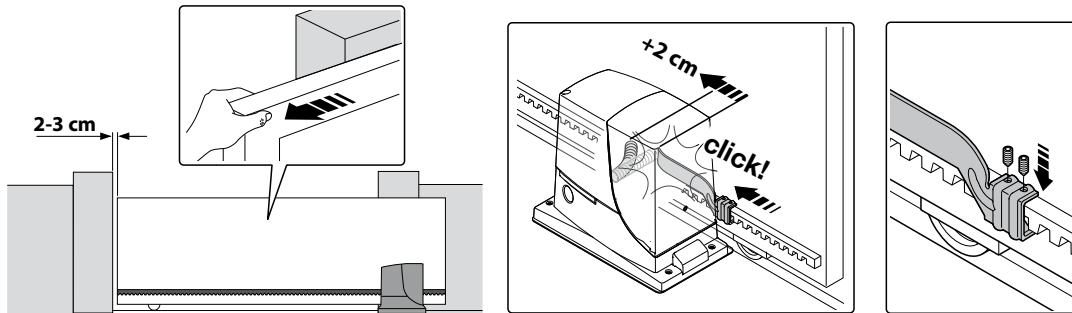

09. Manually lock the gearmotor

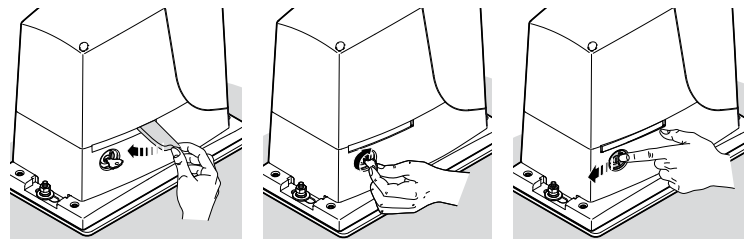

Manually lock the gearmotor.

⚠ IMPORTANT! – The gearmotor is set up (at the factory) for installation on the right (fig. 5); if it must be installed on the left, proceed as shown in fig. 6 (a - b).

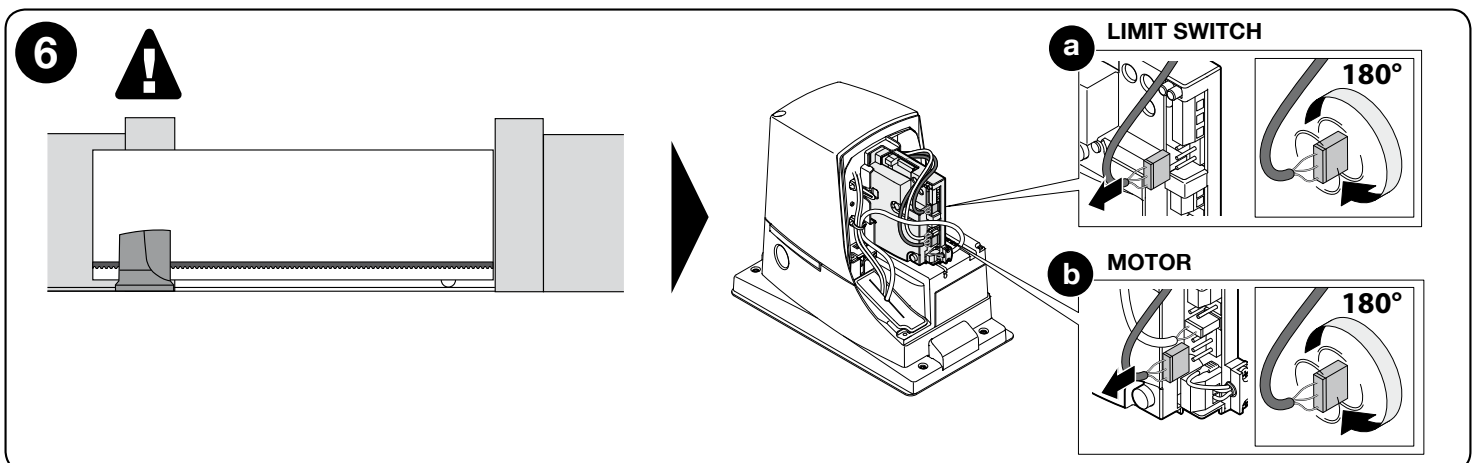
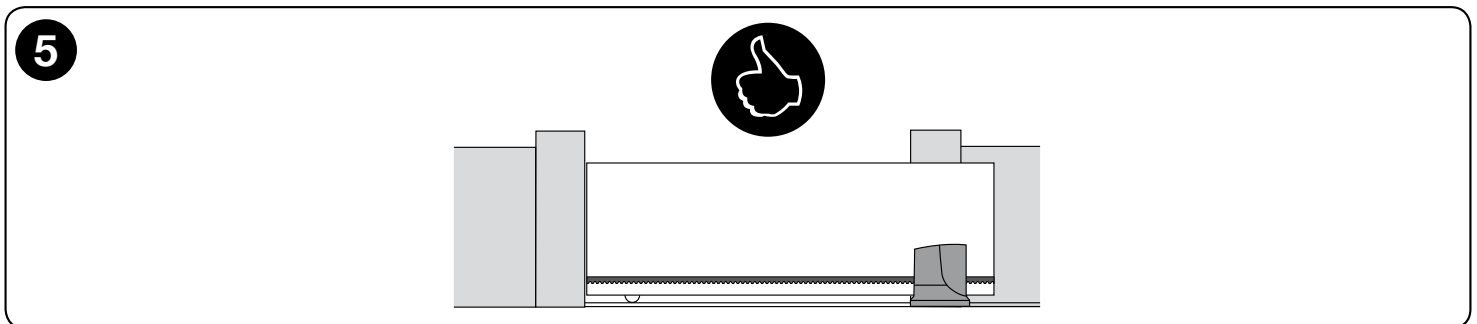

4 ELECTRICAL CONNECTIONS

⚠ CAUTION! - All electrical connections must be made with the system powered off Incorrect connections can result in damage and injury.

Fig. 2 shows the hookup of a typical installation; fig. 7 shows the connections to be made on the control unit.

4.1 - Types of electrical cables

Table 3 - Types of electrical cable (see fig. 2)

	Connection	Type of cable	Maximum length
A	POWER	3 x 1,5 mm ²	30 m *
B C	FLASHER WITH AERIAL	1 cable: 2 x 1,5 mm ² 1 shielded RG58 cable	10 m 10 m (< 5 m recommended)
D	PHOTOCELLS	1 cable: 2 x 0,25 mm ² (TX) 1 cable: 4 x 0,25 mm ² (RX)	30 m 30 m
E - F	KEY SWITCH	1 cable: 2 x 0,5 mm ² **	20 m

* A power supply cable longer than 30 m may be used provided it has a larger gauge, e.g. 3x2.5mm², and that a safety grounding system is provided near the automation unit.

** The two 2 x 0.5 mm² cables can be replaced by a single 4 x 0.5 mm² cable.

4.2 - Electrical cable connections: fig. 7

Table 4 - Description of electrical connections

Terminals	Function	Description
1 - 2	Aerial	- radio receiver aerial input - aerial integrated into flasher; an external aerial can be used if desired
9 - 12	Step-by-step	input for devices which control movement. NO (Normally Open) contacts can be connected
9 - 10	Stop	- input for devices which lock or stop a movement: NC (Normally Closed) contacts may be connected - for further details, refer to par. 8.1
9 - 11	Photo	- input for safety devices which when tripped reverse the gate's direction of movement: NC (Normally Closed) contacts may be used - for further details, refer to par. 8.1.
5 - 4	Flashing light	- flasher output (230 V auto-intermittent) - flashes at regular intervals while the gate is moving: 0.5s on, 0.5s off
Warnings <ul style="list-style-type: none"> • NC (Normally Closed) input: these must be shorted if not used; if more than one contact is to be connected to the stop input, they must be connected IN SERIES; • NO (Normally Open) input: these must be left unconnected if not used; if more than one contact is to be connected to the input, they must be connected IN PARALLEL. • Contacts must be mechanical and disconnected from any voltage. 		
Sensitive edges	No specific input; use Nice equipment: - fixed sensitive edges: use the TCE interface - mobile sensitive edges: use the FT210 unit or IRW interface Refer to the product's instruction manual for details	

To make the electrical hookup, proceed as described below with reference to fig. 7:

01.	Open the cover: undo the screw and raise the cover
02.	Run the power cable through the hole (leave 20/30 cm of free cable) and connect it to its terminal clamp
03.	Run the cables of the equipment to be installed or already present through the provided hole (leave 20/30 cm of free cable) and connect them to their terminal clamps (see fig. 14)
04.	Before closing the cover, program the system: chapter 7
05.	Close the cover and tighten down its bolt

7

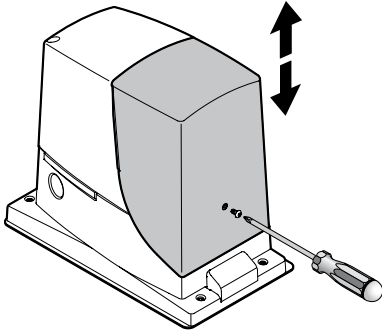

AERIAL	= AERIAL	LIMIT SWITCH	= LIMIT SWITCH
PROGRAM SWITCH	= MICRO SWITCHES	FLASH	= FLASHER
LED RADIO	= RADIO LED	BOOST CAPACITOR	= STARTCONDENSATOR
LED PHOTO	= PHOTOCELL LEDES	RUN CAPACITOR	= CAPACITOR RUN
LED P.P.	= STEP-BY-STEP LED	MOTOR	= MOTOR
LED OK	= OK LED	FUSE	= FUSE
RADIO	= RADIO KEY		

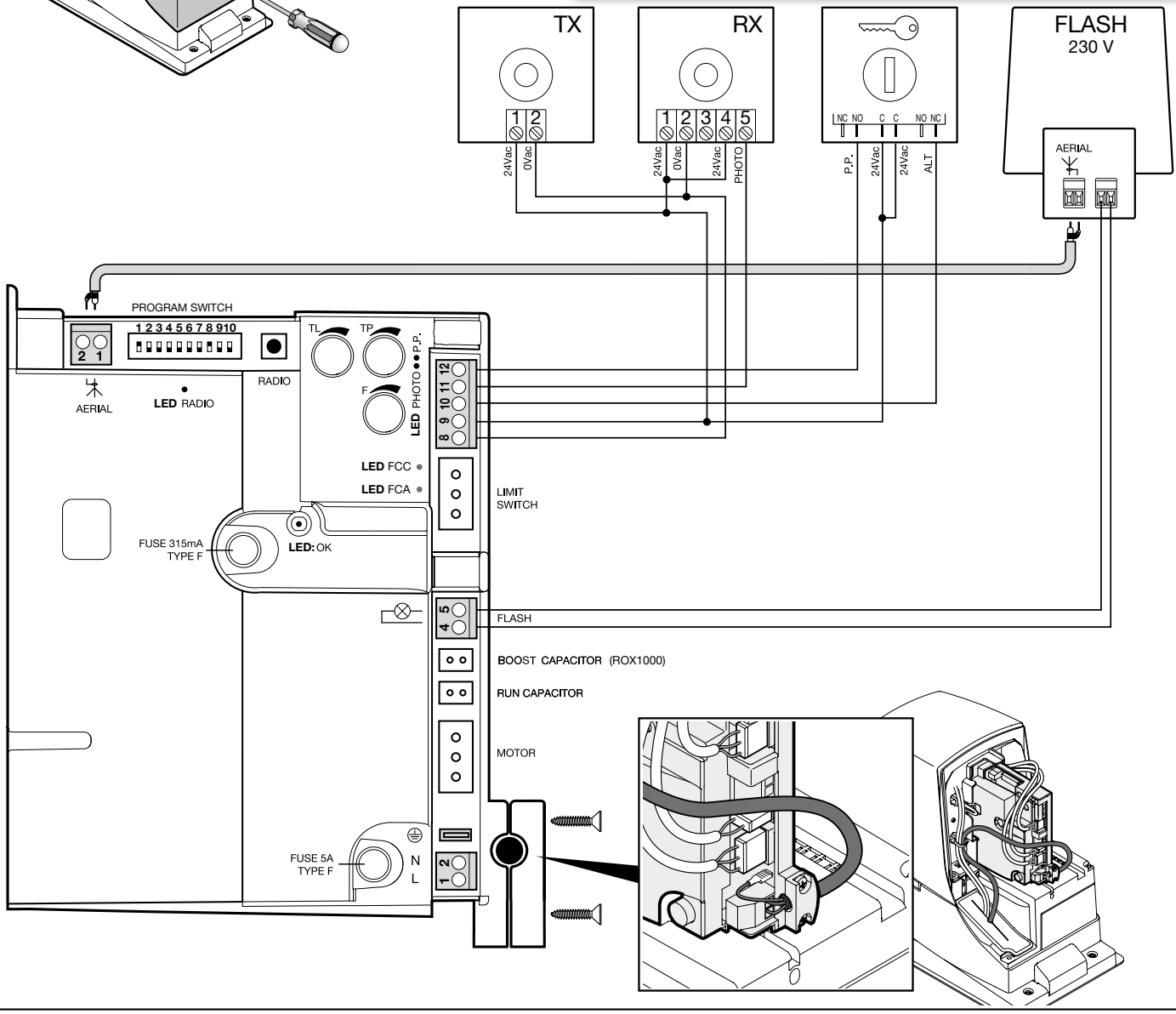

5 STARTING THE AUTOMATION AND CHECKING THE CONNECTIONS

5.1 - Hooking the automation up to the mains

⚠ CAUTION! – The automation must be hooked up to the mains by an expert electrician, in observance of established local regulations.

Proceed as follows

01. Manually release the gearmotor so that the gate can be opened and closed
02. Move the gate to the halfway position

03. Manually lock the gearmotor

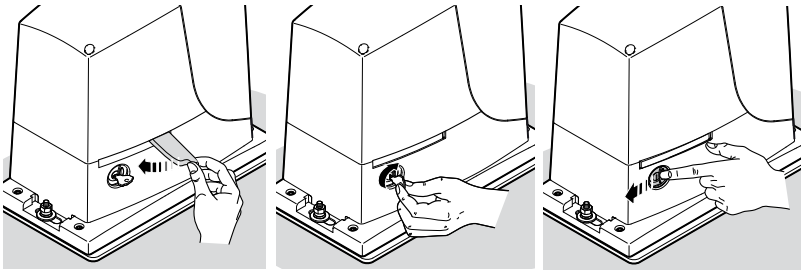

- 04.** Power the automation up and check:
- that the OK led is flashing regularly: 1 flash per second
 - that the gate does not move and that the flasher is off

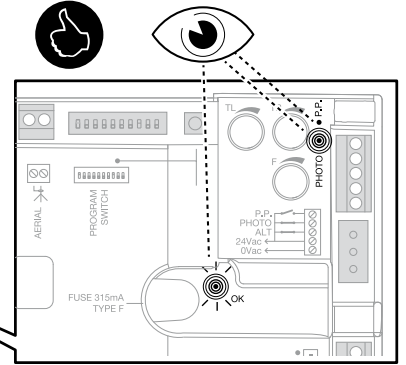
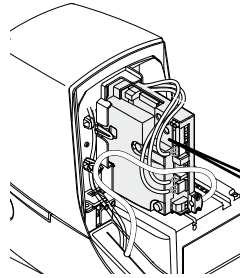

! if any of these conditions are not satisfied, proceed as follows (step 05)

- 05.** Shut off mains power to the automation and check the electrical connections, photocell alignment, and fuses. If necessary, check the limit switch connections: move the limit switch levers and check that the switch trips and turns off the FCA / FCC led on the control unit respectively

6 TESTING AND COMMISSIONING

These are the most important phases of automation set-up to ensure maximum system safety. They must be done by a qualified technician who agrees to run the tests and check the solutions to any risks present, as well as checking compliance with regulations, standards and the law: in particular, the requirements of EN 13241-1, EN 12445 and EN 12453. Any supplementary equipment must be tested separately for operation and interaction with the ROX: refer to the respective user manuals.

6.1 - Testing

The testing procedure can also be performed as a periodic check of the automation devices. Each component of the system (sensitive edges, photocells, emergency stop, etc.) requires a specific testing phase. To do so, follow the procedures given in the instruction manuals. Run the test as follows:

- 01.** Ensure that all specifications in chapter 1 "WARNINGS" have been observed in full

- 02.** Check that the gate can be moved by hand in both directions with a force no greater than the value given in the application limits (Table 1)

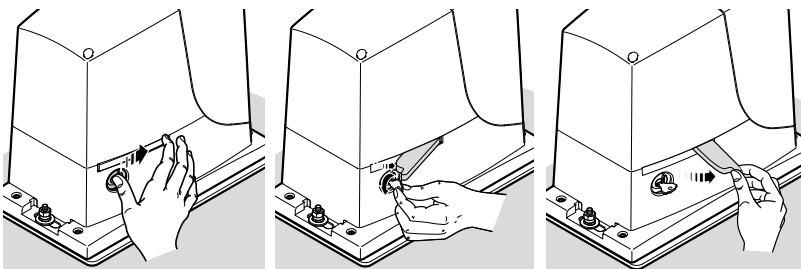

- 03.** Lock the gearmotor

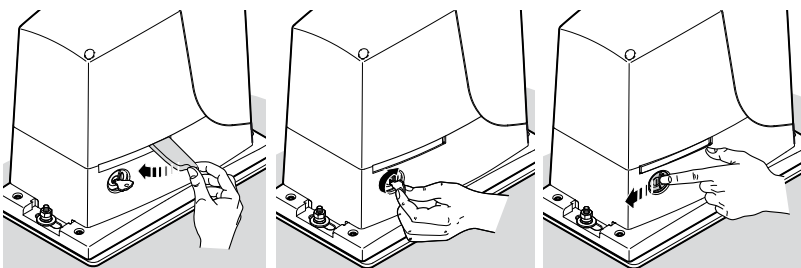

04.	Using the key switch, control key or radio transmitter, test the opening and closing of the gate and make sure that it moves in the intended direction
05.	The test should be carried out a number of times to make sure that the gate moves smoothly, that there are no points of excessive friction and that there are no defects in the assembly or adjustments
06.	Check the operation of the safety equipment, one by one (photocells, sensitive edges, etc.)
07.	Check the operation of the photocells and any interference with other equipment: 1 - pass a dia. 5 cm length 30 cm cylinder along the optical axis, first close to the TX, then close to the RX 2 - check that the photocells trip in any condition, switching from active to alarm and back 3 - check that tripping the photocell results in the intended response of the control unit: e.g., when tripped during a closing stroke, the gate changes direction.
08.	If the dangerous situations caused by the movement of the door have been safeguarded by limiting the force impact, the user must measure the impact force according to the EN 12445 standard. If the adjustment of the “force” is used to assist the system for the reduction of the impact force, try to find the adjustment that gives the best results.











6.2 - Commissioning





Commissioning can take place only after all testing phases have been terminated successfully (par. 6.1).
Partial or “makeshift” commissioning is strictly prohibited.

01.	Prepare and store the technical documentation for the automation for at least 10 years. This must include at least: an assembly drawing of the automation, a wiring diagram, an analysis of hazards and solutions adopted, a manufacturer’s declaration of conformity of all the devices installed (for ROX use the annexed CE declaration of conformity); a copy of the automation system instruction manual and maintenance schedule.
02.	Affix a label or plate permanently to the gate, bearing instructions on how to manually release the gearmotor: use the figures included at the end of the User Manual (tearout insert)
03.	Post a permanent label or sign near the gate containing this picture (min. height 60 mm): 
04.	Using the key switch or radio transmitter, test the opening and closing of the gate and make sure that it moves in the intended direction
05.	Prepare the declaration of conformity of the automation system and deliver it to the owner.
06.	Give the owner the user manual (tearout insert)
07.	Prepare and give the owner the maintenance schedule
08.	The force adjustment is an important safety aspect and must be done with care by an expert technician. Important! - Adjust the force to enable the gate to move as intended; higher forces than this can cause injury to animals and persons or damage to property if the gate collides with an obstacle.
09.	Before commissioning the gate, inform the owner in writing about the attendant residual risks.

7 PROGRAMMING

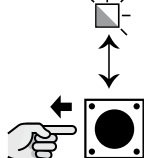
In this manual the programming procedures are explained with the use of icons and their meanings are given in the following glossary:





GLOSSARY			
Symbol	Description	Symbol	Description
	RADIO led on		wait ...
	RADIO led off		observe / check
	RADIO led flashing		press and release the RADIO key
	shut off mains power		hold down RADIO key
	turn on mains power		release RADIO key

	press and release the desired key on the radio transmitter to be memorized		release the RADIO key exactly when the led behaves in the specified manner (on, flashing, off)
	hold down the desired key on the radio transmitter to be memorized		correct procedure
	release the transmitter key		INCORRECT procedure

7.1 - Control unit: programming keys

The control unit has a variety of factory settings which can be reprogrammed: this chapter describes the available functions and how to program them.

The control unit is equipped with microswitches and trimmers (fig.7):

Name	Symbol	Description
PROGRAM SWITCH		Activates a function
Trimmer TL		Sets the Operating Time parameters (see paragraph 7.1.1)
Trimmer TP		Sets the Pause Time parameters' (see paragraph 7.1.1)
Trimmer F		Sets the Force parameters (see paragraph 7.1.1)
RADIO key		Programs the radio receiver

Factory settings (default)

MICRO SWITCHES:

Semiautomatic (1 = ON)



Trimmer **TL** (Operating Time)

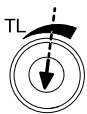

Trimmer **TP** (Pause Time)

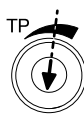

Trimmer **F** (Force)

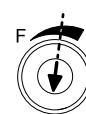

7.1.1 - Trimmer (TL - TP - F)

The control unit's parameters can be adjusted with three trimmers (fig. 7)

TL (Operating Time)

Operating mode	Adjustment
sets the maximum duration of an Open or Close movement	01. select ' Semiautomatic ' or ' Automatic ' and set micro switch 1 to ' ON '
	02. set trimmer TL to the mid position
	03. run a full Open and Close cycle: check that the maximum duration setting (Open / Close) is high enough and that a margin of 2 or 3 seconds remains. Adjust trimmer TL to its maximum setting if necessary. N.B.: if this time is not sufficient, cut the TLM jumper next to trimmer TL (fig. 7) to obtain a 'Long Operating Time' (TLM)

Slow down function: to use this function, activate the programmable function "slow down" and set trimmer TL so that the slow down phase starts 50/70 cm before the gate trips the limit switch.

N.B.: the result of an adjustment to this parameter is visible during the first Open movement run after the modification has been made.

TP (Pause Time)	
Operating mode	Adjustment
sets the time between the end of an Open movement and the start of the next Close movement	01. select 'Automatic' and set micro switch 2 to 'ON'
	02. set trimmer TP to the desired value;
	03. to check the time setting, run a full Open movements and see how long it takes before the Close movement starts.
F (Force)	
⚠ CAUTION! – Adjustments to this parameter are safety critical: take great care when making this adjustment.	
To adjust the parameter, try various settings: you must measure the force applied by the gate when moving and compare it with local regulations.	

7.2 - Programmable functions

The control unit has a set of micro switches (PROGRAM SWITCH - fig. 7) which activate functions to adapt the automation to the user's needs as well as making it safer to use.

The micro switches select the operating modes and program the functions, as described in Table 5.

To activate/deactivate a function:

Micro switches (1 ... 10)	ACTIVATE	DEACTIVATE
	ON	OFF
IMPORTANT! - some functions are safety critical; make sure to check which function is safest.		

Table 5

Switches 1-2	Operation
Off-Off	Manual (hold-to-run)
On-Off	Semiautomatic
Off-On	Automatic (automatic closing)
On-On	Automatic + Always Closes
Switch 3	Operation
On	Condominium (not available in manual mode)
Switch 4	Operation
On	Pre-flashing
Switch 5	Operation
On	Closes 5 seconds after 'Photo' if set to 'Automatic' or 'Close after Photo' if set to 'Semiautomatic'
Switch 6	Operation
On	Safety "Photo" also when Opening
Switch 7	Operation
On	Gradual Start-up
Switch 8	Operation
On	Slow down
Switch 9	Operation
On	Brake
Switch 10	Operation
Off	Not used

Switches 1-2:

Manual operation	the movement is only executed while the control is active (transmitter key held to run).
Semiautomatic operation	sending a command executes the entire movement until the operating time expires or the gate trips the limit switch.
Automatic operation	after an Open, the system pauses and then automatically Closes the gate.
Always Closes operation	follows a power failure: if, when power is restored, the control unit determines that the gate is open, it automatically flashes the flasher for five seconds and then runs a Close cycle.

Switch 3:

Condominium function	when a "Step-by-Step" command is sent and the gate starts to Open, it cannot be stopped by any other "Step-by-Step" or Open command sent by radio until it has completed. When closing, on the other hand, sending a new Step-by-Step command will stop and reverse the movement.
-----------------------------	--

Switch 4:

When a command is sent, the flasher starts flashing and, after 5 seconds (2 seconds in Manual mode), the movement starts.

Switch 5:

This function, when set in Automatic mode, holds the gate open only for the time required for vehicles or pedestrians to pass through it; when the Photo device is cleared, the movement stops and a Close movement starts after a 5 second delay.

If the functions is set in Semiautomatic mode, when the photocells are tripped while the gate is closing, automatic Close is activated with the programmed Pause Time.

Switch 6:

The Foto function is usually active only during Close movements; if micro switch 6 is set to "ON", tripping the photocell interrupts Open movements too. On the other hand, in Semiautomatic or Automatic modes, the Open movement starts again as soon as the photocell clears.

Switch 7

This function activates a soft start to gate movements to prevent them moving jerkily.

Switch 8:

Slow down, which reduces the speed to 30% of its nominal value, reduces the impact force of the gate at the end of a movement. When this function is active, yo must adjust the operating Time (TL) since the start of the slow down phase is linked to this setting. Set the TL so that the slow down starts 50-70 cm before the limit switch is tripped. The slow down function not only reduces the speed of the gate but also the torque exerted by the motor (by 70%). CAUTION – In automations which demand a high motor torque, setting this function can stop the motor.

Switch 9:

This function brakes the motor at the end of a movement; the effect is moderate at first, but increases to quickly and smoothly stop the gate.

Switch 10:



Not used.

7.3 - Integrated radio receiver

For remote control operation, the control unit has an integral radio receiver (433.92 MHz compatible with FLO, FLOR, OPERA, and HCS SMILO coding)

Since the coding systems are different, the first transmitter to be memorised determines the type of transmitter memorised thereafter.

- To modify the coding family, proceed as indicated in 'Total deletion of the receiver's memory' - par. 8.3.
- To check whether the receiver has already memorised any transmitters, and to determine the type of coding, proceed as follows:

<p>01.  to control unit</p> <p>02.  to control unit</p> <p>03. count the number of green flashes emitted by the receiver and refer to table 7</p>	<p>Table 7</p> <table border="1"> <thead> <tr> <th>Flash</th> <th>Coding</th> </tr> </thead> <tbody> <tr> <td>1</td> <td>Flo</td> </tr> <tr> <td>2</td> <td>O-Code / FloR / TTS</td> </tr> <tr> <td>3</td> <td>Smilo</td> </tr> <tr> <td>4</td> <td>no transmitter memorised</td> </tr> </tbody> </table>	Flash	Coding	1	Flo	2	O-Code / FloR / TTS	3	Smilo	4	no transmitter memorised
Flash	Coding										
1	Flo										
2	O-Code / FloR / TTS										
3	Smilo										
4	no transmitter memorised										

7.3.1 - Memorisation of radio transmitters

Each radio transmitter is recognised by the radio receiver by means of a "code" which is different from that of any other transmitter. There are two types of memorisation: Mode 1 and Mode 2.

- **Mode 1:** automatically assigns the commands indicated in table 8 to the transmitter's keys.



Each transmitter is memorised in a single step, with all keys programmed: it does not matter which key is pressed. (One memory location is occupied for each key).

N.B.: when memorised in Mode 1, a transmitter can control only one automation.

Table 8	
Transmitter key	Command
1	Step-by-step
2	STOP
3	Open
4	Close

N.B.: single-channel transmitters have only key 1; two-channel transmitters have keys 1 and 2

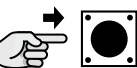
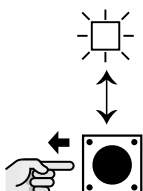

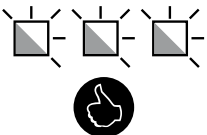







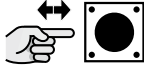







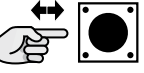







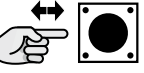







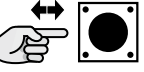

Mode 1 memorisation

01.	02.	03.	04.
 x 4s		within 10s  x 3s	
RADIO KEY	RADIO KEY AND LED	TRANSMITTER DESIRED BUTTON	RADIO LED

• **Mode 2:**
freely assigns a command among those listed in table 9.
 For each phase, only one key is memorised (the one pressed during memorisation).
 (One memory location is occupied for each key).

Table 9	
Transmitter key	Command
1	Step-by-step
2	STOP
3	Open
4	Close

Mode 2 memorisation

	01.	02.	03.	04.
Step-by-step	 x 1	 	within 10s  x 3s	   
STOP	 x 2	  	within 10s  x 3s	   
Open	 x 3	   	within 10s  x 3s	   
Close	 x 4	    	within 10s  x 3s	   
	RADIO KEY	RADIO LED	KEY IN QUESTION TRANSMITTER	RADIO LED

N.B.: if you wish to memorise other transmitters, repeat step 03 within 10 sec. The memorisation procedure terminates after 10 sec if no other operations are run

7.3.2 - "Remote" memorisation

You can memorise a new transmitter without having to operate the receiver key (10-20 m from the receiver).







You must have a previously memorised transmitter (old). The new transmitter will be memorised with the same characteristics as the old one.

⚠ Important! Remote memorisation may be done on all receivers within the range of the transmitter; therefore, only the one involved in the operation should be kept switched on.

Standard procedure

⚠ During the procedure, if the old transmitter was memorised in:

- Mode 1 → press any key
- Mode 2 → press the key you wish to memorise

01.	With the motor stopped, stand close to the control unit
02.	NEW transmitter  * x 5s 
03.	OLD transmitter already memorised  x 1s  x 1s  x 1s
04.	NEW transmitter  * x 1s









If the procedure terminated successfully the new transmitter is memorised

* same key as NEW transmitter

Alternative procedure

⚠ During the procedure, if the old transmitter was memorised in:

- Mode 1 → press any key
- Mode 2 → press the key you wish to memorise











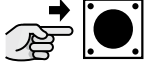



01.	With the motor stopped, stand close to the control unit
02.	NEW transmitter  * x 3s 
03.	OLD previously memorised transmitter  ** x 3s 
04.	NEW transmitter  * x 3s 
05.	OLD previously memorised transmitter  ** x 3s  not visible remote 

If the procedure terminated successfully the new transmitter is memorised

* same key as NEW transmitter

** same key as OLD transmitter

Deleting radio transmitters

01.	02.	03.	04.
	   	   	     
RADIO KEY	RADIO LED RADIO LED	RADIO KEY AND LED	RADIO KEY AND LED

8.1 - Adding or removing devices

You can add or remove devices at any time.

STOP input

Input that stops movement immediately, followed by a brief reverse of the manoeuvre.

You may connect devices with NC contacts to this input; multiple devices can be connected in series.

N.B.: when the NC contact opens, the automation stops and reverses its direction briefly.

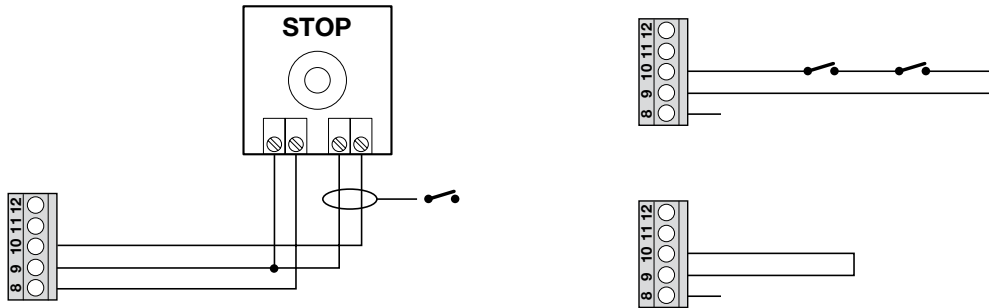

Photocells

To add a pair of photocells, proceed as follows:

01. Power up the receivers (RX) via terminals 8 - 9

02. Connect the receiver's NC contact in series with the NC contact already connected to control unit terminals 9 - 11.

⚠ If using two pairs of photocells, to prevent them interfering with each other, activate the synchronisation function described in the respective user manual.

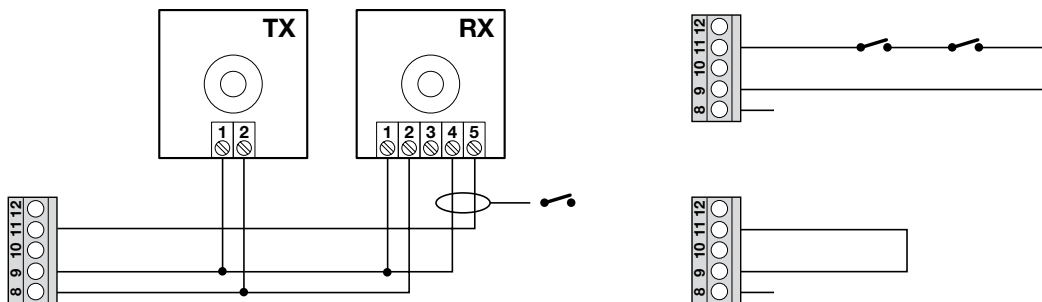

8.2 - Power for external devices

To power external devices (transponder badge reader, or backlighting for a keyswitch) connect the device to the control unit as shown in the figure.

The power supply voltage is 24Vac -20% ÷ +30% with a maximum available current of 100mA.

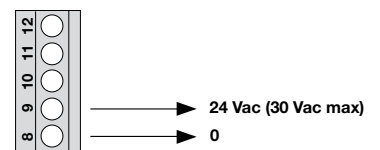

8.3 - Total deletion of the receiver's memory

To cancel all memorised transmitters or all data in the receiver's memory, proceed as follows:

01.	02.	03.	04.
<p>RADIO KEY</p>	<p>RADIO LED</p>	<p>RADIO KEY AND LED</p>	<p>RADIO KEY AND LED</p>

8.4 - Diagnostics

Some devices are display messages to identify their status and faults.

8.4.1 - Control unit signals

The leds on the control unit issue signals to indicate their normal/faulty operation.

Table 10 lists the signals:

Table 10

OK LED	Cause	Solution
Off	Malfunction	Make sure there is power supply; check to see if the fuses are blown; if necessary, identify the reason for the failure and then replace them with others of the same type
On	Serious malfunction	There is a serious malfunction; try switching off the control unit for a few seconds; if the condition persists, it means there is a malfunction and the circuit board has to be replaced
One flash every second	All OK	Normal operation of control unit
2 quick flashes	The status of the inputs has changed	This is normal when there is a change in one of the inputs: Step-by-Step, STOP, triggering of photocells or the radio transmitter is used
PHOTO led	Cause	Solution
Off	Photocell input activated	At the start of the manoeuvre, one or more photocells are preventing movement; check to see if there are any obstacles, also check the NC connection for faults.
On	All OK	The photocell is aligned and the movement is permitted
FCA and FCC leds	Cause	Solution
Off	Activation of the STOP input	Check the devices connected to the STOP input
On	All OK	STOP Input active

9 DISPOSAL OF THE PRODUCT

This product constitutes an integral part of the automation system, therefore it must be disposed of together with the former.

As in installation, also at the end of product lifetime, the disassembly and scrapping operations must be performed by qualified personnel. This product is made up of different types of material, some of which can be recycled while others must be disposed of. Seek information on the recycling and disposal systems envisaged by the local regulations in your area for this product category.

⚠ CAUTION! – Some parts of the product may contain polluting or hazardous substances which, if disposed of into the environment, constitute serious environmental and health risks.



As indicated by the symbol, the product may not be disposed of as domestic waste. Sort the materials for disposal, according to the methods envisaged by current legislation in your area, or return the product to the retailer when purchasing an equivalent product.

⚠ CAUTION! - Local legislation may include the application of serious fines in the event of improper disposal of this product.

10 WHAT TO DO IF...

In case of malfunction due to problems during installation or failure of parts, refer to table 11:



Table 11

Problem	Solution
The radio transmitter does not control the gate and the led on the transmitter does not light up	Check to see if the transmitter batteries are exhausted, if necessary replace them
The radio transmitter does not control the gate but the led on the transmitter lights up	Check to see if the transmitter has been memorised correctly in the radio receiver. Check that the emission of the transmitter radio signal is correct by means of this empirical test: push a key and rest the LED on the aerial of a normal radio (ideally an economical one) that is switched on and tuned in, as close as possible, to 108.5Mhz FM; a slight crackling sound should be heard
No manoeuvre starts and the OK LED fails to flash.	Check that the product is being supplied 230 V mains power Check to see if fuses F1 and F2 (fig. 7) have blown; if necessary, identify the reason for the failure and then replace the fuses with others that have the same current rating and specs
No manoeuvre starts and the flasher is off	Check that the command is actually received: if the command reaches the Step-by-Step input, the OK led flashes twice to indicate that the command has been received

11 MAINTENANCE

To keep the system safe and ensure a long service life, it must be serviced regularly: at most every 6 months or after 20,000 movements since the last service.

⚠ CAUTION! – The maintenance operations must be performed in strict compliance with the safety directions provided in this manual and according to applicable legislation and standards.

01.		Check for any deterioration in automation system components, paying special attention to erosion or oxidation of the structural parts. Replace any parts which are below the required standard.
02.		Check the wear and tear on the moving parts: pinion, rack and the gate components; if necessary replace them.
03.		Run all the tests and checks indicated in par. 6.1 - Testing.

12 TECHNICAL SPECIFICATIONS

⚠ All technical specifications stated herein refer to an ambient temperature of 20° C (± 5° C). • Nice S.p.a. reserves the right to apply modifications to products at any time when deemed necessary, maintaining the same intended use and functionality.

	ROX600	ROX1000	ROX1000/V1
Type	Electromechanical gear motor for the automatic movement of sliding gates for residential use, complete with electronic control unit		
Pinion Z	15; Modulus: 4; Pitch: 12.5 mm; Primitive diameter: 60 mm		
Peak thrust	18 Nm	24 Nm	24 Nm
Nominal torque	9 Nm	9 Nm	12 Nm
Speed (no load)	11 m/min	11 m/min	13 m/min
Nominal torque speed	8.5 m/min	8.5 m/min	8.5 m/min
Operating cycles	20 cycles/hour	20 cycles/hour	25 cycles/hour
Maximum continuous operating time	4 minutes		
Nominal power supply	230 V - 50/60 Hz	230 V - 50/60 Hz	120 V - 60 Hz
Nominal power	300 W	350 W	350 W
Electrical isolation class	1 (a safety grounding system is required)		
Flasher output	For 1 flashing light 230 V auto-intermittent		
STOP input	For NC contacts (a variation with respect to the closed state causes the command "STOP").		
Step-by-step Input	For NO contacts (closing of the contact causes the "STEP-BY-STEP" command)		
PHOTO input	For NC contacts (a variation with respect to the closed state causes a change of direction during closing when the photocell is occluded)		
Radio AERIAL Input	52 Ω for RG58 or similar type of cable		
Radio receiver	Incorporated		
Operating temperature	-20°C - 50°C		
Protection class	IP 44		
Dimensions (mm) and weight	330 x 210 x 303 h; 11 kg		
Dimensioni (mm) e peso	330 x 210 x 303 h; 11 kg		
Integrated radio receiver			
Type	4 channel receiver for incorporated radio command		
Frequency	433.92MHz		
Transmitter compatibility	FLO, FLOR, OPERA, HCS SMILO... coding		
Transmitters memorized	Up to 1024 if memorized in mode 1		
Input impedance	52Ω		
Sensitivity	better than 0.5 μV		
Range of the transmitters	From 100 to 150 m. The range can vary if there are obstacles or electromagnetic disturbances, and is affected by the position of the receiving aerial		
Outputs	For the controls listed in tables 8 and 9		
Operating temperature	-20°C - 50°C		

CE Declaration of Conformity

**Declaration in accordance with the following Directives:
2004/108/EC (EMC); 2006/42/EC (MD) Annex II, part B**

Note: The contents of this declaration correspond to declarations in the official document filed in the offices of Nice S.p.a. and, in particular, the latest version thereof available prior to the printing of this manual. The text herein has been re-edited for editorial purposes. A copy of the original declaration can be requested from Nice S.p.A. (TV) I..

Declaration number: **532/ROX**

Revision: **0**

Language: **EN**

Manufacturer's Name: NICE S.p.A.

Address: Via Pezza Alta 13, 31046 Rustignè di Oderzo (TV) Italy

Person authorized to compile the technical documentation: NICE S.p.A.

Type of product: Electromechanical gearmotor with incorporated control unit

Model / Type: ROX600, ROX1000

Accessories:

The undersigned Mauro Sordini, as Chief Executive Officer, hereby declares under his own responsibility that the product identified above complies with the provisions of the following directives:

- The model conforms to Directive 1999/5/EC OF THE EUROPEAN PARLIAMENT AND OF THE COUNCIL of 9 March 1999 on radio equipment and telecommunications terminal equipment and the mutual recognition of their conformity, in accordance with the following harmonised standards:

- Health and safety (Art. 3(1)(a)): EN 62479:2010

- Electrical safety (Art. 3(1)(a)): EN 60950-1:2006+A1:2010+A12:2011+A1:2010+A2:2013

- Electromagnetic compatibility (Art. 3(1)(b)): EN 301 489-1 V1.9.2:2011, EN 301 489-3 V1.6.1:2013

- Radio spectrum (Art. 3(2)): EN 300 220-2 V2.4.1:2012

Pursuant to Directive 1999/5/EC (Annex V), the product is rated Class 1

- The model conforms to DIRECTIVE 2004/108/EC OF THE EUROPEAN PARLIAMENT AND OF THE COUNCIL of 15 December 2004 on the approximation of the laws of the Member States relating to electromagnetic compatibility and repealing Directive 89/336/EEC, in accordance with following harmonised standards:

EN 61000-6-2:2005, EN 61000-6-3:2007 + A1:2011

In addition, the product conforms to the following directive in accordance with the provisions applicable to partly completed machinery: Directive 2006/42/EC OF THE EUROPEAN PARLIAMENT AND COUNCIL of May 17 2006 regarding machines and amending directive 95/16/EC (consolidated text)

– It is hereby declared that the relevant technical documentation has been compiled in accordance with Annex VII Part B of Directive 2006/42/CE and that the following essential requirements have been applied and fulfilled: 1.1- 1.1.2- 1.1.3- 1.2.1-1.2.6- 1.5.1-1.5.2- 1.5.5- 1.5.6- 1.5.7- 1.5.8- 1.5.10- 1.5.11

– The manufacturer undertakes to transmit, in response to a reasoned request by the national authorities, relevant information on the partly completed machinery. This shall be without prejudice to the intellectual property rights of the manufacturer of the partly completed machinery.

– Should the partly completed machinery be put into service in a European country with an official language different to the one used in this declaration, a translation into that language must be provided by the person bringing the machinery into the language area in question

– The partly completed machinery may not be put into service until the final machinery into which it is to be incorporated has been declared in conformity with the provisions of Directive 2006/42/EC, where appropriate.

The product also complies with the following standards:

EN 60335-1:2002 + A1:2004 + A11:2004 + A12:2006 + A2:2006 + A13:2008+A14:2010+A15:2011, EN 60335-2-103:2003+A11:2009

All parts of the product subject to the following standards comply with them:

EN 13241-1:2003+A1:2011, EN 12445:2002, EN 12453:2002, EN 12978:2003+A1:2009

Oderzo, 28 april 2015

Ing.Mauro Sordini
(Chief Executive Officer)

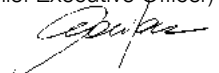

Operation manual (to be given to the final user)

- When you first use the automation, the installation technician must inform you about the origin of the residual risks and you must take time to read this user manual.
 - Make sure to keep this user manual (delivered by the installation technician) for future reference and for hand-over to any further owner of the automation.
 - Your automation system is a machine that will faithfully execute your commands; unreasonable or improper use may generate dangers: do not operate the system if there are people, animals or objects within its range of operation.
 - **Children:** automation systems are designed to guarantee high levels of safety and security. They are equipped with detection devices that prevent movement if people or objects are in the way, guaranteeing safe and reliable activation. However, it is advisable to ensure that children do not play in the vicinity of the automation; remote controls should always be kept out of reach. It is not a toy!
 - **Checking the system:** in particular all cables, springs and supports to detect possible imbalance, signs of wear or damage.
 - Check that the system is safe every month using the safety equipment with sensitive edges.
 - Do not use the automation if repairs or adjustments are required; any fault or an incorrectly balanced gate may lead to physical injury.
 - **Malfunctions:** if the automation is malfunctioning, shut off its power supply. Never attempt any repairs; contact your local installer for assistance.
 - The system can be operated manually: release the gearmotor, as described in “Manual release and lock”.
 - Do not modify the system or its programming and adjustment parameters in any way, even if you feel capable of doing it: your installation technician is responsible for the system.
 - The final test, the periodic maintenance operations and any repairs must be documented by the person who has performed them; these documents must remain under the custody of the owner of the system.
- Important:** have the system repaired as soon as possible if the safety equipment is malfunctioning. Transit is admitted only if the gate is completely open and stationary.
- **Disposal:** At the end of the automation's lifetime, ensure that it is disposed of by qualified personnel and that the materials are recycled or scrapped according to current local regulations for this category of product.
 - **Maintenance:** As with all machinery, the automation requires periodic maintenance to ensure optimal operation, extended lifetime and complete safety. Arrange a periodic maintenance schedule with your installation technician. Nice recommends that maintenance checks be carried out every six months for normal domestic use, but this interval may vary depending on the intensity of use. Only qualified personnel are authorised to carry out checks, maintenance operations and repairs.

• Manually locking the gearmotor

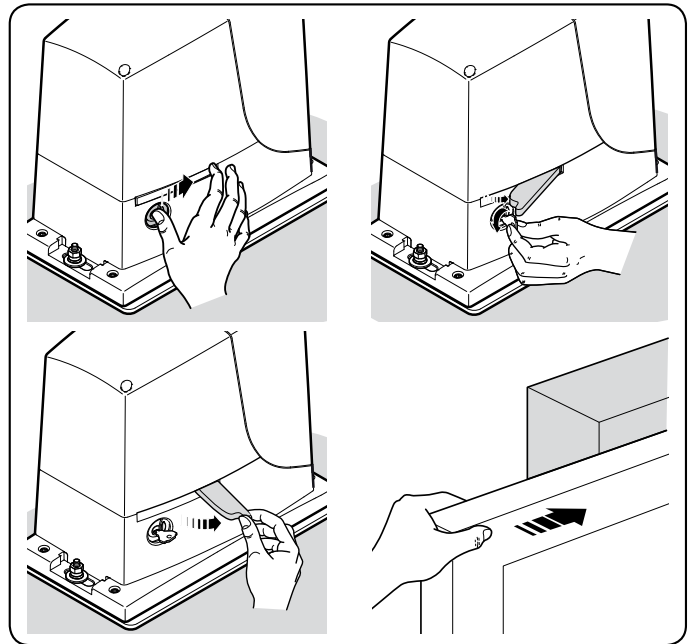

• Manually locking the gearmotor

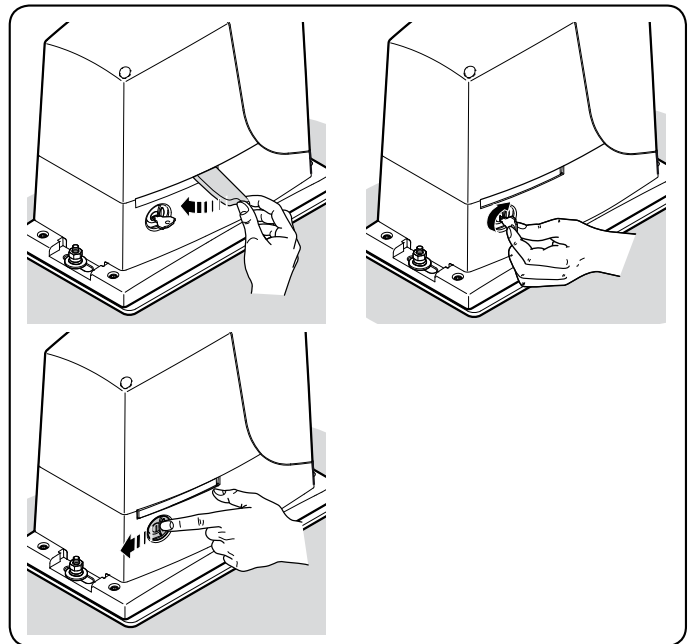



Nice SpA
Oderzo TV Italia
info@niceforyou.com

www.niceforyou.com

IDV0378A03EN_18-12-2015_DIGITAL VERSION